

Simpson panel instruments...

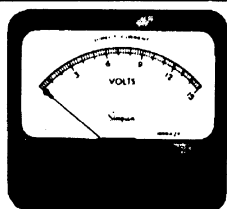

4 1/2" RECTANGULAR

1325 STOCK TYPES

... plus **HUNDREDS MORE**, custom-built
from standing tools *

INSTRUMENTS THAT STAY ACCURATE

* Send us your special meter requirements today. Let our top-flight engineers work out solutions or make recommendations based solely to your needs.

YOUR ELECTRONIC PARTS DISTRIBUTOR
HAS HUNDREDS IN STOCK!

Simpson ELECTRIC COMPANY

5200 Wood Kinzie St., Chicago 44, Ill. Phone: EDinbrook 9-1121
In Canada: Bach-Simpson, Ltd., London, Ontario

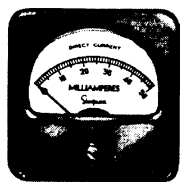

2 1/2" RECTANGULAR
ACCURACY: ± 2%

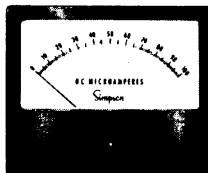

6" RECTANGULAR
ACCURACY: ± 2%

See the Simpson
ADD-A-TESTER ADAPTERS
they will increase the
versatility of your
260 or 270 VOM'S.

TRANSISTOR TESTER

Model 650 \$26.95

DC VTVM

Model 651 \$32.95

TEMPERATURE TESTER

Model 652 \$38.95

AC AMMETER

Model 653 \$18.95

AUDIO WATTMETER

Model 654 \$18.95

MICROVOLT ATTENUATOR

Model 655 \$18.95

BATTERY TESTER

Model 656 \$19.95

MILLIOHMMETER

Model 657 \$39.95

DC AMMETER

Model 661 \$17.95

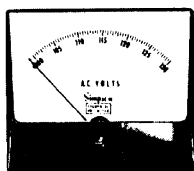

1 1/2", 2 1/2", 3 1/2", 4 1/2"
WIDE VUE
ACCURACY: ± 2%



2 1/2" or 3 1/2" ROUND
ACCURACY: ± 2%



EDGEWISE
ACCURACY: DC ± 2%
SCALE LENGTH: 1 1/4"

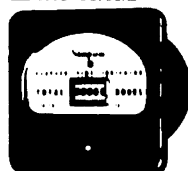

**ELAPSED TIME
INDICATOR**
110/220 VOLTS

OPERATOR'S MANUAL

VOLT-OHM-MILLIAMMETER

260[®] SERIES 4

AND

260[®] SERIES 4M

Courtesy Of:
Simpson260.com

SIMPSON ELECTRIC COMPANY

5200 W. Kinzie St., Chicago, Illinois 60644
Area Code 312, Telephone 379-1121
In Canada, Bach-Simpson, Ltd., London, Ontario

Copyright 1963
1-64 - ORU - B & L - Rev. 1

Printed in U.S.A.
1-110197

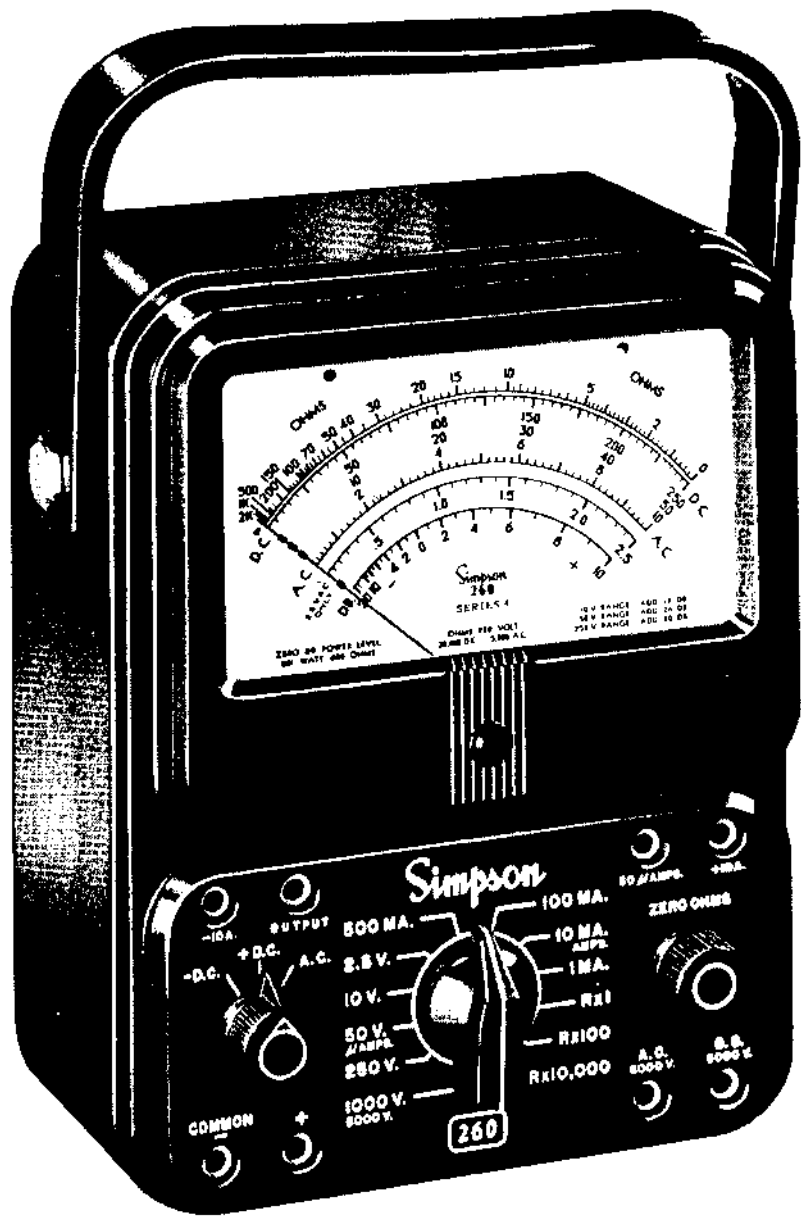

FIG. 1 SIMPSON VOLT - OHM-MILLIAMMETER
260®, SERIES 4

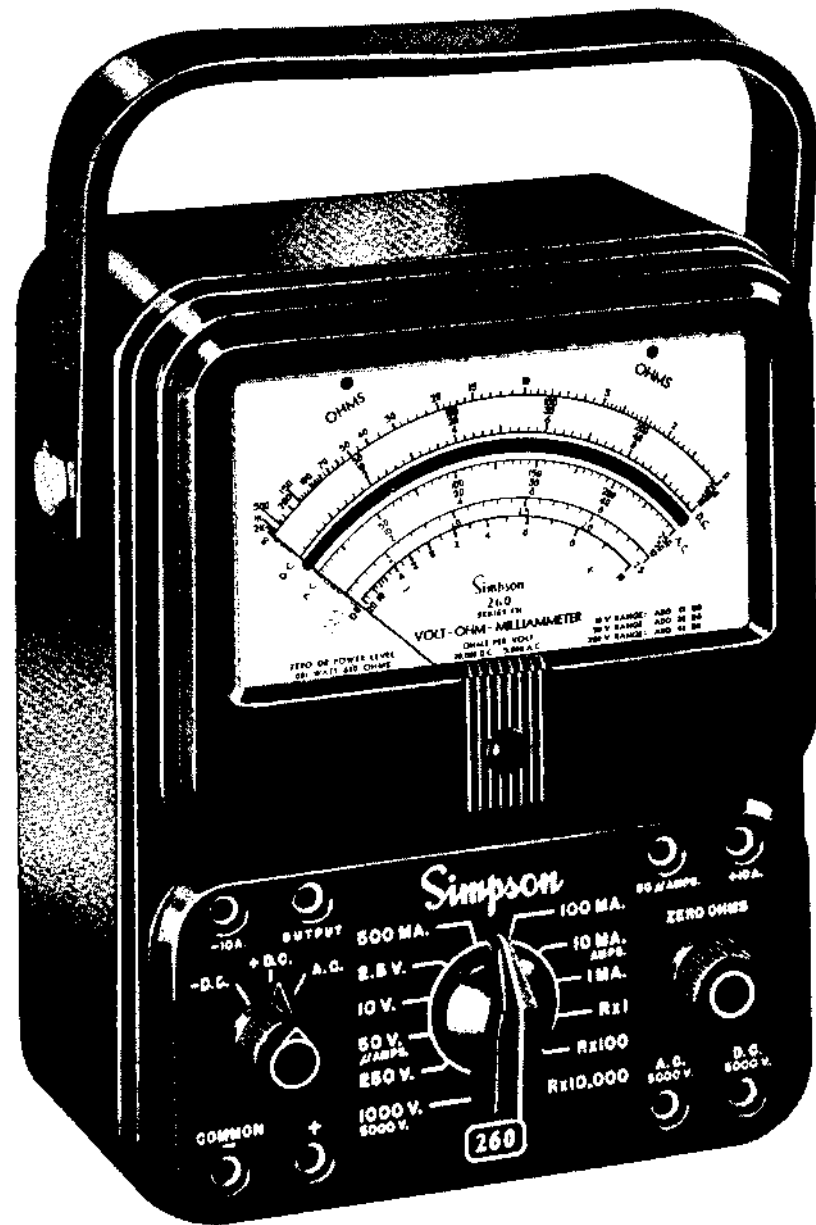

FIGURE 2 SIMPSON VOLT - OHM-MILLIAMMETER
MODEL 260®, SERIES 4 M

SECTION I

GENERAL DESCRIPTION

The Simpson Volt-Ohm-Milliammeters 260[®] Series 4 and Series 4M are identical electrically and mechanically except the Series 4M is equipped with a mirrored dial. Therefore, they are treated as one and the same in this manual.

The 260[®] Series 4 is a rugged, accurate, compact, easy to operate instrument. It is used to measure electrical characteristics of circuits and circuit components. It indicates quantity measurements for D.C. and A.C. voltages, D.C. currents, resistances, decibels, and output voltages.

The Simpson 260[®] Series 4 is an improved version of the dependable 260-3. It incorporates a completely new, rugged, self-shielding, high torque, annular meter movement. The Annular Movement in addition to being self-shielded, is also equipped with spring backed jewel screws. This type of jewel allows the instrument to withstand more abuse due to shock and vibration without increasing the frictional error.

The 260[®] Series 4 also incorporates a special calibration circuit to increase its accuracy. This allows us to provide you with a more accurate unit to begin with. Should the unit get out of adjustment it facilitates its return to the original factory accuracy.

The 260[®] Series 4, has been designed to utilize the most modern components and circuit techniques. It is manufactured by skilled workmen, using high quality materials, in our modern plants, where we use the best machines, tools

and test equipment that money can buy. It will therefore, take considerable abuse and still continue to function. However, it does contain a very precise instrument movement and therefore, we urge that you treat it with the care it deserves. If you will keep it clean, free from continuous severe vibration, avoid dropping it and subjecting it to high electrical overloads; the 260[®] Series 4 will give you many years of trouble-free dependable service.

PHYSICAL

FRONT PANEL

The instrument has a large easy-to-read 4½" meter at the top of the front panel. Below the meter are three operating controls and eight circuit jacks. All switch positions and circuit jacks are labeled with white lettering on black phenolic to insure a long time readability.

RANGE SWITCH

The range switch, in the center of the lower part of the front panel, has 12 positions. It may be turned in either direction to obtain any desired range and circuit position. There are six voltage ranges for D.C. and six for A.C., six ranges for direct current, and three resistance ranges.

FUNCTION SWITCH

The function switch is located at the left hand side of the lower part of the front panel. It has three positions: -D.C., +D.C., and A.C. When direct current, D.C. voltage, or resistance is to be measured, the function switch may be set at -D.C. or +D.C., depending on the polarity of current or voltage. Reversing the test lead connections without

General Description

removing them from the circuit under test is accomplished by use of the function switch.

ZERO OHMS

The control at the lower right on the panel is marked ZERO OHMS. This variable resistance in the ohmmeter circuit will be used to compensate for the aging of the internal batteries. Use it to adjust the meter indication to zero (at the right end of the scale) with the test leads shorted together whenever the ohmmeter circuit is used.

CIRCUIT JACKS

There are eight jacks, two being located in each corner of the front panel. These are the connection points for the test leads. Plug the prods of the test leads into the proper jacks to obtain the circuit and range desired for each application.

At the lower left are COMMON- and + jacks. These are the jacks that will be used most. Connect the black test lead to COMMON- for all circuits and ranges except 10 amperes D.C. Connect the red test lead to the + jack for all circuits and ranges except those designated by the other circuit jacks.

Across the top of the panel are jacks marked -10 A., OUTPUT, 50 μ AMPS, and +10 A. For all audio frequency output voltage ranges, use the red test lead connected to the OUTPUT jack. For the 50 microampere or 250 millivolt D.C. range, use the red test lead connected to the 50 μ AMPS jack. For the 10 ampere D.C. range, use the black test lead in the -10 A. jack and the red test lead in the +10 A. jack.

General Description

PHENOLIC CASE

The Simpson 260,[®] Series 4, is housed in a heavy black reinforced case. It is molded with heavy reinforced walls for maximum durability. All the component parts in the 260,[®] Series 4, are attached or mounted to the front panel; the entire instrument slips into and out of the case in one piece.

PRINTED CIRCUIT

Conforming to the latest engineering developments, almost all the component parts of the Simpson 260,[®] Series 4, are mounted in a printed circuit. This simplifies assembly, reduces maintenance, and extends the useful life of the instrument.

ADJUST-A-VUE HANDLE

The comfortable handle is attached on each side of the instrument case. The handle may be used to support the instrument in a convenient sloping position for easy viewing on the bench top. Of course, the 260[®] Series 4 can also be placed in either a vertical or horizontal position.

TEST LEADS

Each Simpson Volt-Ohm-Milliammeter 260,[®] Series 4, is furnished with one pair of four-foot test leads. One lead is black and the other red for easy polarity identification. The wire is very finely stranded and extra-flexible. Its insulation is a special high-grade rubber which has far more insulation strength than the largest voltages to which your instrument will ever be subjected.

TEST LEAD INSPECTION

Periodic inspection of the test leads is recommended to detect cuts, burns or other damage that could reduce the insulation strength of the leads. When replacement is indicated, ask your local distributor for catalog number 7500.

General Description

FUSE PROTECTION

The Simpson Volt-Ohm-Milliammeter 260[®], Series 4, is provided with a fuse which protects the tester circuits from misuse on the ohmmeter ranges and from excess of overload on the milliamperes ranges.

SIZE AND WEIGHT

The 260[®], Series 4, measures 5-1/4 by 7 by 3-1/8 inches. It weighs 3-1/2 pounds.

ELECTRICAL

MEASUREMENT RANGES

D.C. VOLTAGE

Accuracy in % of F.S.

Sensitivity; 20,000 ohms-per-volt

0- 250 millivolts	2%
0- 2.5 volts	2%
0- 10 volts	2%
0- 50 volts	2%
0- 250 volts	2%
0-1000 volts	2%
0-5000 volts	3%

A.C. VOLTAGE

Accuracy in % of F.S.

Sensitivity; 5,000 ohms-per-volt

0- 2.5 volts	3%
0- 10 volts	3%
0- 50 volts	3%
0- 250 volts	3%
0-1000 volts	3%
0-5000 volts	4%

General Description

DIRECT CURRENT

Accuracy in % of F.S.

0- 50 microamperes	1.5%
0- 1 milliampere	2%
0- 10 milliamperes	2%
0- 100 milliamperes	2%
0- 500 milliamperes	2%
0- 10 amperes	2%

D.C. RESISTANCE

Accuracy in degrees of ARC

R x 1 for 0-2000 ohms (12 ohms center)	2.5°
R x 100 for 0-200,000 ohms (1200 ohms center)	2.0°
R x 10,000 for 0-20 megohms (120,000 ohms center)	2.0°

A.F. OUTPUT VOLTAGE

With 0.1 μ f internal series capacitor

0- 2.5 volts
0- 10 volts
0- 50 volts
0- 250 volts

VOLUME LEVEL IN DECIBELS

With zero DB equal to 1 milliwatt across a 600 ohm line

-20 to +10 DB
- 8 to +22 DB
+ 6 to +36 DB
+20 to +50 DB

General Description

INTERNAL BATTERIES

There are five 1.5 volt batteries inside the instrument. These are used for the ohmmeter circuits. One large cell is used to furnish 1.5 volts for the R x 1 and R x 100 ranges. Four smaller cells are added in series to furnish 7.5 volts for the R x 10,000 range.

Each battery is held in place with two special spring clips, which also serve as battery contacts. The polarity symbols are marked on the panel. Always observe polarity when you replace the batteries in the instrument.

FREQUENCY RESPONSE

Your Simpson 260[®], Series 4, has an excellent frequency response for A.C. and A.F. voltage measurements. It is essentially "flat" through the range from 20 cycles per second up to 50,000 cycles per second.

SECTION II

OPERATING INSTRUCTIONS

CAUTION

When making voltage or current measurements, as a personal protection, form the habit of turning off all power to the circuit under test. Connect the test leads at the desired points in the circuit. Then turn on the power while taking readings. Turn off the power before disconnecting the test leads from the circuit.

Operating Instructions

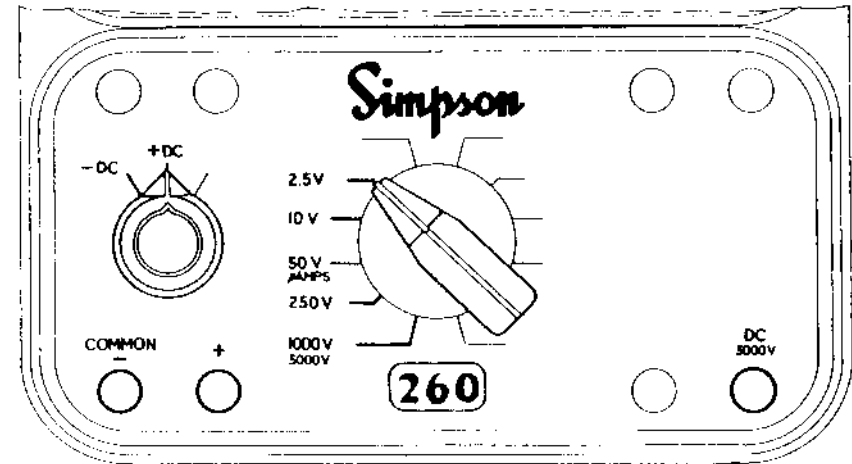

CONTACTS AND SWITCH POSITIONS FOR D.C. VOLTS.

ADJUST POINTER FOR ZERO

Before any measurements are made, check to see that the pointer indicates zero when the meter is in its operating position. If the pointer is off zero, adjust the screw located in the phenolic case below the center of the meter scale, as shown in Figure 1. Use a small screwdriver to turn this screw slowly clockwise or counterclockwise until the pointer is exactly over the zero mark at the left side of the scale.

D.C. VOLTAGE MEASUREMENTS, 0-250 MILLIVOLT RANGE ONLY

CAUTION

Be extremely careful when using the 260[®], Series 4, as a millivoltmeter, to prevent damage to the meter. An excessive voltage applied to the meter when in

Operating Instructions

this type of application could be detrimental to the meter movement.

1. Set the function switch at +D.C.
2. Connect the black test lead in the COMMON— jack and the red test lead in the 50 μ AMPS jack.
3. Set the range switch at 50 μ AMPS (common position with 50 V.).
4. Connect the black test lead to the negative side of the circuit to be measured, and the red test lead to the positive side of the circuit.
5. Read the voltage on the black arc marked D.C., and use the figures marked 0–250; read directly in millivolts.
6. Turn off power in the circuit which is being measured before disconnecting meter leads.

D.C. VOLTAGE MEASUREMENTS, 0–1000 VOLTS

1. Set the function switch on the left hand side of the front panel at +D.C.
2. Plug the black test lead into the COMMON – jack and the red test lead into the + jack.
3. Set the range selector switch in any of the five voltage range positions. These are marked 2.5 V., 10 V., 50 V., 250 V., and 1000 V. When in doubt as to the voltage present, always use the highest voltage range as a protection to the instrument. Observe the meter reading. If the voltage is within a lower range, the switch may

Operating Instructions

be set for the lower range to obtain a more accurate reading.

4. Connect the black test lead to the negative side of the circuit to be measured and the red test lead to the positive side of the circuit.
5. Turn on the power in the circuit to be tested. If the pointer deflects to the left of zero, the anticipated polarity is opposite the actual circuit polarity. Turn off the power in the circuit which is being tested. Set the function switch at –D.C., and turn on the power again. This will correct the polarity as applied to the meter.
6. Read the voltage on the black arc marked D.C. which is second from the top of the dial.

For the 2.5 V. range use the 0–250 figures and divide by 100.

For the 10 V., 50 V., and 250 V. ranges read the figures directly on the scale.

For the 1000 V. range use the 0–10 figures and multiply by 100.

7. Turn off the power in the circuit which is being measured before disconnecting meter leads.

D.C. VOLTAGE MEASUREMENTS, 5000 VOLT RANGE

WARNING

Be extremely careful when working in high voltage circuits. Do not touch the meter or test leads while power is on in the circuit being measured.

1. Set the function switch at +D.C.
2. Set the range selector switch at 5000 V.

Operating Instructions

3. Connect the black test lead into the COMMON – jack and the red test lead into the D.C. 5000 V. jack.
4. Be sure power is off in the circuit to be measured and all capacitors have been discharged; connect the black test lead to the negative side of the circuit to be measured and the red test lead to the positive side of the circuit.
5. Turn on the power in the circuit. Do not touch the meter or test leads. If the pointer deflects to the left side of zero, the anticipated polarity is opposite the actual circuit polarity. Turn off the power in the circuit being tested. Set the function switch at –D.C., and turn on the power again. This will correct the polarity as applied to the meter.
6. Read the voltage using the 0–50 figures on the black arc which is second from the top of the scale. Multiply the reading by 100.
7. Turn off the power before disconnecting the test leads.

NOTE: To measure higher D.C. Voltage, see section IV for high voltage accessory probes.

MEASURING A.C. VOLTAGES TO 1000 VOLTS

The Simpson Volt-Ohm-Milliammeter 260,[®] Series 4, measures A.C. voltage in terms of the R.M.S. value of a sine wave. This is accomplished by using two germanium diodes in a modified full wave bridge circuit.

The 260, Series 4, has been especially designed to give a wide frequency response, making it useful over a range from 10 cycles per second to 500,000 cycles per second. The curve which follows shows the response of the 2.5, 10, and 50 volt ranges. The 2.5 and 10 volt ranges are within 5% from 10 to 100 kilocycles.

Operating Instructions

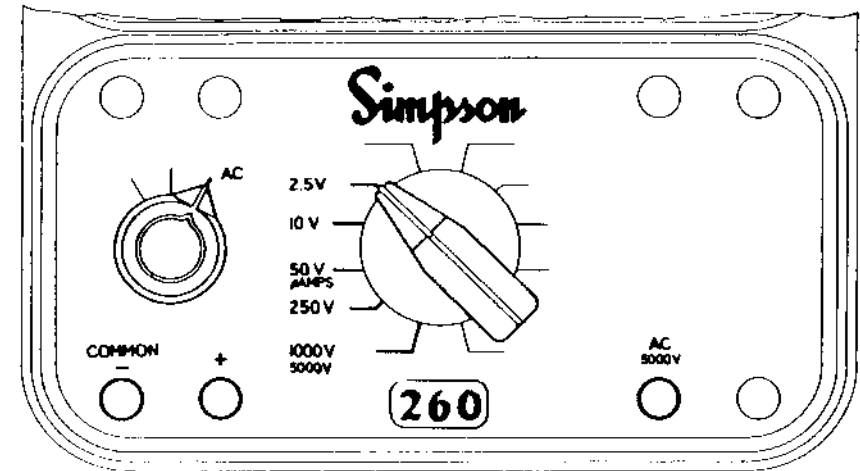

CONTACTS AND SWITCH POSITIONS FOR A.C. VOLTS.

1. Set the function switch at A.C.
2. Set the range selector switch in any of the five voltage range positions, marked 2.5 V., 10 V., 50 V., 250 V., and 1000 V. When in doubt as to the voltage present, always use the highest voltage range as a protection to the instrument. Observe the meter reading. If the voltage is within a lower range, the switch may be set for the lower range to obtain a more accurate reading.
3. Plug the black test lead into the COMMON – jack and the red test lead into the + jack.
4. Be sure power is turned off in the circuit to be measured and connect the test leads across the voltage source.
5. Turn on the power in the circuit to be measured.
For the 0–2.5 V. range read the value directly on the special arc marked 2.5 V.A.C. ONLY.

Operating Instructions

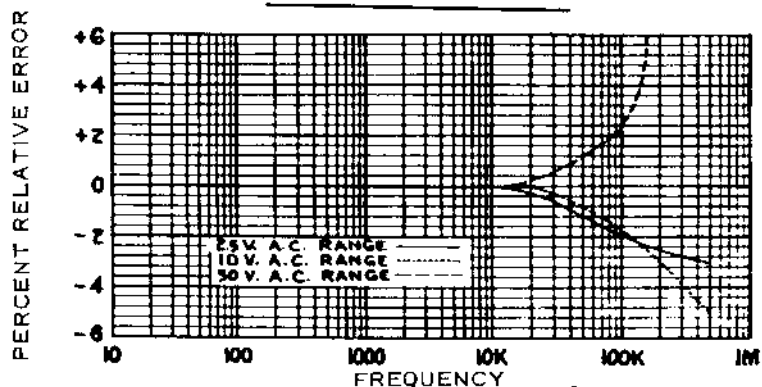

FREQUENCY RESPONSE FOR 260[®] Series 4

For the 10 V., 50 V., and 250 V. ranges read the red arc marked A.C. and use the black figures immediately above the arc.

For the 1000 V. range read the red arc marked A.C. Use the 0 – 10 figures and multiply by 100.

MEASURING A.C. VOLTAGE TO 5000 VOLTS

WARNING

Be extremely careful when working in high voltage circuits. Do not touch the meter or test leads while power is on in the circuit being measured.

1. Set the function switch at A.C.
2. Set the range selector switch at 5000 V.
3. Connect the black test lead into the COMMON – jack and the red test lead into the A.C. 5000 V. jack.
4. Be sure the power is off in the circuit to be measured and that all its capacitors have been discharged. Connect the test leads into the circuit.
5. Turn on the power in the circuit to be measured. Do not

Operating Instructions

touch the meter or test leads.

6. Read the voltage on the red arc marked A.C. Use the 0 – 50 figures and multiply by 100.
7. Turn off the power before disconnecting the test leads.

MEASURING OUTPUT VOLTAGES

An output voltage is the A.C. component only, when there is a mixture of A.C. and D.C. voltages. This occurs mostly in amplifier circuits.

The 260[®] Series 4, has a capacitor in series with the OUTPUT jack. This blocks the D.C. component of the current in the measuring circuit, but allows the A.C. or desired component to pass on to the meter circuit. The blocking capacitor placed in series with the A.C. voltage measuring circuits alters the A.C. response. The following curves show the frequency range over which the accuracy is within $\pm 10\%$. However, the instrument is useful up to 600 kilocycles per second.

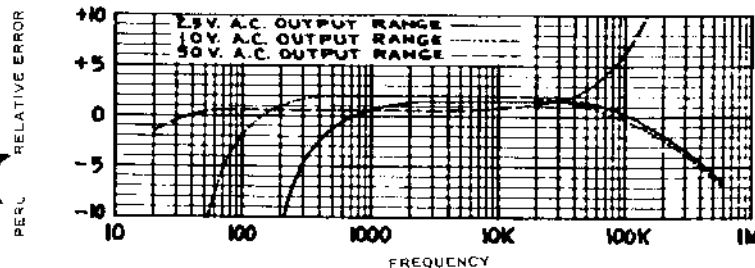

ACCURACY FOR OUTPUT MEASUREMENTS.

1. Set the function switch on the left hand side of the front panel at A.C.

Operating Instructions

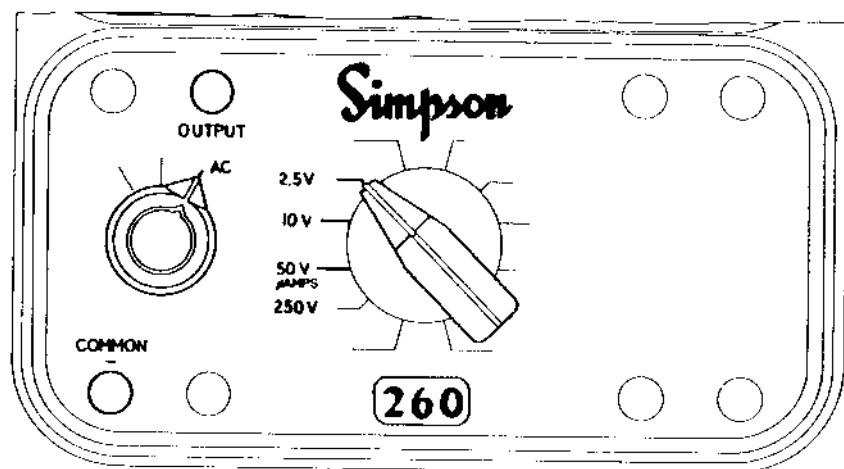

CONTACTS AND SWITCH POSITIONS FOR OUTPUT

2. Connect the black test lead in the COMMON - jack and the red test lead in the OUTPUT jack.
3. Set the range selector switch at the desired range position. These are marked 2.5 V., 10 V., 50 V., and 250 V.
4. Connect the black test lead to the grounded side of the circuit to be measured and the red test lead to the "hot" side.
5. Turn on the power in the circuit. Read the output voltage on the A.C. voltage arcs of the dial.
For the 0-2.5 V. range read the value directly on the special arc marked 2.5 V. A.C. ONLY.
For the 10 V., 50 V., and 250 V. ranges use the red arc marked A.C. and read the black figures immediately above the arc.
6. Turn off the power in the circuit before disconnecting the leads.

Operating Instructions

MEASURING DECIBELS

For some applications, output voltages and audio frequency voltages are frequently measured in terms of decibels. The decibel scale (DB), at the bottom of the dial, is numbered from -20 through 0 to +10.

To measure decibels, read the DB arc after proceeding according to instructions for A.C.

The DB readings obtained will be correct on an absolute scale if you are using a 0 DB power level of .001 watt in 600 ohms, and if the voltage which you read was measured across 600 ohms.

To obtain absolute DB values across 600 ohms:

For the 10 V. range read the DB arc and add +12 DB to the reading.

For the 50 V. range read the DB arc and add +26 DB to the reading.

For the 250 V. range read the DB arc and add +40 DB to the reading.

If the reference level is 0 DB = .006 watt in 500 ohms, subtract (+)7 DB from the reading to obtain the absolute value of decibels.

OHMMETER CIRCUIT

When resistances are measured in ohms, the batteries inside the case furnish power for the circuit. Since the batteries are subject to deterioration over long periods of time, there is a compensating circuit in the ohmmeter to make it possible to extend the useful life of the batteries.

Operating Instructions

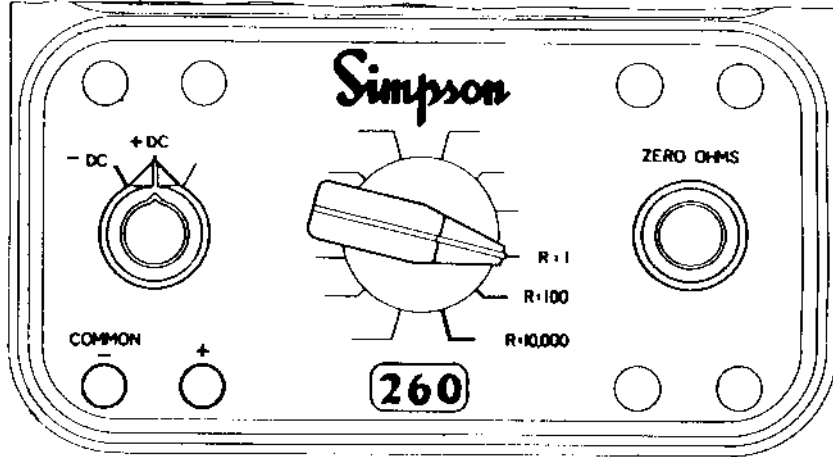

CONTACTS AND SWITCH POSITIONS FOR RESISTANCES.

ZERO OHMS ADJUST

Each time you use the ohmmeter circuit, check the zero indication on the meter before you measure any resistance. Check and adjust it each time you switch to a different range. To set the ZERO OHMS control, proceed as follows:

1. Set the range switch at one of the resistance range positions and the function switch at either -D.C. or +D.C.
2. Connect the black test lead in the COMMON - jack and the red test lead in the + jack.
3. Clip the contact end of the test leads together to short out the resistance circuit.
4. Observe the meter indication. It should read 0 on the right hand end of the OHMS arc, which is at the top of the dial.

Operating Instructions

5. If the pointer does not read 0, rotate the ZERO OHMS knob until it does. If you cannot bring the pointer far enough to read 0, one or more batteries need to be replaced.
6. When the pointer shows zero, unclip the shorted test leads; the ohmmeter circuit is now ready to measure resistance.

MEASURING RESISTANCES

To measure resistance, proceed as follows:

1. Set the range switch in one of the resistance range positions.
 - Use R x 1 for resistance readings from 0 to 200 ohms.
 - Use R x 100 for resistance readings from 200 to 20,000 ohms.
 - Use R x 10,000 for resistance readings above 20,000 ohms.
2. Set the function switch at either -D.C. or +D.C.
3. Connect the black test lead in the COMMON - jack and the red test lead in the + jack.
4. Short the test leads together and adjust for zero ohms (see instructions above).
5. Separate the test leads and connect them across the resistance which is to be measured. If there is a "forward" and "backward" resistance such as in rectifiers, switch back and forth between the two D.C. positions of the function switch to reverse this polarity.

NOTE

The resistance of such rectifiers will measure different values on different resistance ranges of the

Operating Instructions

260[®], Series 4, Thus, a crystal diode which measures 80 ohms, for example, on the R x 1 range may measure 300 ohms on the R x 100 range. This is normal, and is a result of the diode characteristic. The difference in values does not indicate any fault in the ohmmeter.

6. Read the indication on the OHMS arc at the top of the dial. Note that this arc reads from right to left for increasing values.
7. Multiply the reading by the multiplier factor at the switch position for the resistance value in ohms. "K" on the dial stands for "thousand".

MEASURING DIRECT CURRENTS, 0 TO 50 MICROAMPERES

CAUTION

Never connect the test leads directly across any voltage when the 260[®], Series 4, is used as a current meter, except when it is used as a 0 - 250 millivoltmeter. This would damage the instrument. Always connect the meter in series with the load across the voltage source.

1. Set the function switch at +D.C.
2. Connect the black test lead in the COMMON - jack and the red test lead in the 50 μ AMPS jack.
3. Set the range switch at 50 μ AMPS (common position with 50 V.).
4. Open the circuit in which the current is to be measured. Connect the meter in series with the circuit. Connect

Operating Instructions

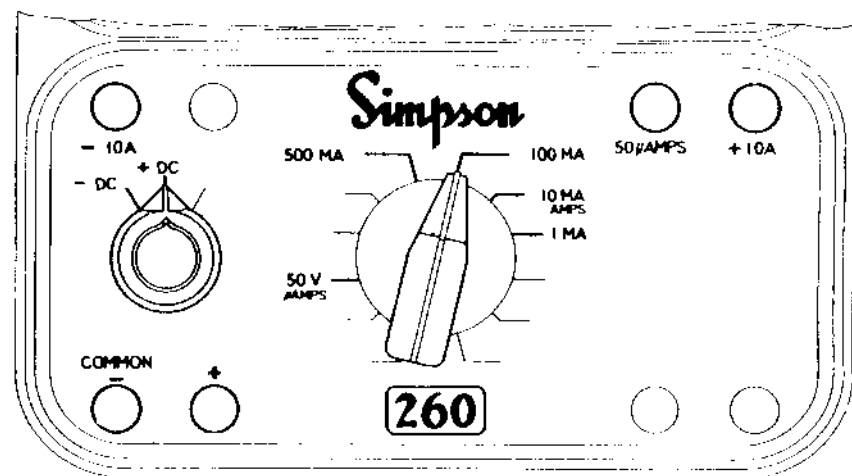

CONTACTS AND SWITCH POSITIONS
FOR DIRECT CURRENTS.

the red test lead toward the positive side, and the black test lead toward the negative side.

5. Turn on the power in the circuit which is to be measured. Observe the meter. If the pointer is deflected to the left, the current polarity is opposite to that which was anticipated. Turn off the power and reverse leads.
6. Read the current directly on the black D.C. arc. Use the 0 - 50 figures. The current value is shown in microamperes.
7. Turn off the circuit power. Remove the test leads and restore the circuit continuity.

MEASURING DIRECT CURRENTS, 0 TO 500 MILLIAMPERES

1. Set the function switch at +D.C.
2. Connect the black test lead in the COMMON - jack and the red test lead in the + jack.

Operating Instructions

3. Set the range switch in any of the four range positions required. These are marked 1 MA., 10 MA., 100 MA., and 500 MA.
4. Open the circuit which is to be measured. Connect the meter in series with the circuit. Connect the red test lead toward the positive side and the black test lead toward the negative side.
5. Turn on the power in the circuit which is to be measured. Observe the meter. If the pointer is deflected to the left, the current polarity is opposite to that which was anticipated. Turn off the power, set the function switch at -D.C., and then turn on the power again.

6. Read the current directly on the black D.C. arc.

For the 1 MA. range use the 0-10 figures and divide by 10.

For the 10 MA. range use the 0-10 figures directly.

For the 100 MA. range read the 0-10 figures and multiply by 10.

For the 500 MA. range read the 0-50 figures and multiply by 10.

The current values are in milliamperes.

7. Turn off the circuit power. Remove the test leads and restore circuit continuity.

MEASURING DIRECT CURRENTS.

0 TO 10 AMPERES

1. Connect the black test lead in the -10 A. jack and the red test lead in the +10 A. jack.
2. Set the range selector switch at 10 AMPS (common with 10 MA.).

Operating Instructions

3. Open the circuit which is to be measured. Connect the meter in series with the circuit. Connect the red test lead toward the positive side and the black test lead toward the negative side.
4. Turn on the power in the circuit which is to be measured. Observe the meter. If the pointer is deflected to the left, the current polarity is opposite to that which was anticipated. Turn off the power, reverse the test lead connections, and turn on the power again.

NOTE

The function switch has no effect on polarity for the 10 AMP range.

5. Read the current directly on the black D.C. arc. Use the 0-10 figures. The current values are in amperes.
6. Turn off the circuit power. Remove the test leads and restore circuit continuity.

SECTION III

MAINTENANCE

HOW TO OPEN THE CASE

The case of the Simpson Volt-Ohm-Milliammeter 260[®], Series 4, has been designed to provide easy and quick access to the inside for all necessary adjustment and replacement of parts. Use a 1/4-inch screwdriver to remove the four screws through the bottom of the case. Then slip the entire front panel straight forward out of the case. The meter, the front panel, the printed circuit, and the batteries are all attached together and will come out as a unit.

Maintenance

BATTERY REPLACEMENT

There are five batteries inside the case of the Model 260,[®] Series 4. They are used to supply power for resistance measurements. One is a large size (#2, Size D) flashlight cell, and the other four are smaller (#Z) flashlight cells. When it is no longer possible to bring the pointer to 0 for the R x 1 and R x 100 ranges (see ZERO OHMS ADJUST, page 17), replace the large cell with a fresh one. When it is no longer possible to bring the pointer to 0 on the Rx10,000 range, replace the four smaller cells with fresh ones. This will restore operation of the ohmmeter circuit.

NOTE: When batteries reach the end of their useful life, they should be replaced promptly. Failure to do so may result in extensive damage to your Model 260,[®] Series 4 due to battery leakage, even though the battery may be advertised as "Leakproof."

OBSERVE POLARITY

When you replace the cells, be sure to observe the polarity of the battery circuit. The cells are held each in place with specially designed spring clips which also act as battery contacts. Battery polarity is shown on the panel.

SUB-PANEL PARTS PLACEMENT

Beneath each resistor on the printed circuit is its part number, as it is shown on the schematic diagram and in the parts list. This mark will eliminate any doubt which may arise as to the location of any of the resistors.

RECTIFIER REPLACEMENT AND RECALIBRATION

There are two small rectifiers which are located at the top of the printed circuit, near the large 1.5 volt cell. These are used to rectify the A.C. voltages for measurement. They are shown as D-1 and D-2 in the overall schematic diagram, Fig. 2.

Maintenance

Both rectifiers act in the meter circuit to effectively create a full wave rectifying action. If either or both should fail, the meter will show incorrect indications.

In case of rectifier failure, replace the defective rectifier with another 1N87G, and be sure to observe polarity when you connect it into the circuit. If a type 1N87G is not available use any good quality small crystal rectifier as a replacement.

After you replace either or both rectifiers, test the accuracy of A.C. voltage indications. If necessary, recalibrate the circuit by adjusting rheostats R-28 and R-31 as follows:

1. Set the function switch at A.C. and the range switch at 250 V.
2. Connect the red test lead in the + jack and the black test lead in the COMMON - jack.
3. From a standard voltage source, apply 250 volts A.C. to the red and black test leads. Adjust rheostat R-31 (which is next to the + meter stud on the printed circuit board) so the meter reads full scale. Turn power off.
4. Set the range switch to 2.5 V. Apply 2.5 volts A.C. to the red and black test leads. Adjust rheostat R-28 (which is next to R-31) so the meter reads full scale. Turn power off.

If no standard voltage supply is available for the above procedure, use this alternate method:

1. Set the function switch at A.C., and the range switch at 2.5 V.
2. Connect the red test lead in the + jack and the black test lead in the COMMON - jack.

Maintenance

3. Connect the test leads to a fresh 1.5 volt flashlight cell. Connect the red test lead to the positive post of the battery and the black test lead to the negative post.
4. Adjust rheostat R-28 fully clockwise. It is located in the extreme upper left hand corner of the printed circuit board, next to the "+6 V" mark.
5. Rheostat R-31 is located next to R-28, toward the center of the printed circuit board. Adjust it so the meter reads 1.8 volts on the 2.5 V.A.C. ONLY arc.
6. Adjust R-28 so the meter pointer moves back to 1.71 volts on the same arc (the pointer will indicate 6 on the OHMS scale when it is in this position).

RESISTOR REPLACEMENT

Almost all of the resistors for the Simpson 260[®], Series 4, are mounted on the rear of the printed circuit. This makes them easily accessible for trouble-shooting and repair.

When it is necessary to replace any of the resistors in the circuit, first obtain an exact equivalent resistor. Order it from your nearest Simpson Parts Depot (see page 37) and specify the Simpson part number as it is shown in the parts list. Then clip the defective resistor off the printed circuit board, leaving the leads in the board to use as connections for the replacement.

Carefully twist the leads for the new resistor around the leads left from the defective resistor, and solder each connection. Trim away all excess and see that you have not caused any short circuit to any other part nearby.

Maintenance

REMOVING THE PRINTED CIRCUIT

When you require access to the under-side of the printed circuit, or to the parts which are located between it and the front panel, remove the printed circuit.

To remove the printed circuit, use the following procedure:

1. Set the function switch at +D.C. and the range switch at 2.5 V.
2. Remove the knob for the ZERO OHMS control.
3. Remove the two screws through the lower part of the printed circuit board.
4. Remove the two hex nuts from the meter studs on the top of the printed circuit board.
5. Carefully pry out the battery contact at the + terminal for the small 1.5 volt cells. This is connected to the upper left hand corner of the printed circuit board with an orange lead.
6. Lift the printed circuit board away from the front panel. The entire board, with the switch wafers in place, will come up in one piece.
7. After removal, do not turn knobs on front panel or move any rotors on switches until reassembled.

FUSE REPLACEMENT

Remove the front panel from the case and disconnect the burned-out fuse, using a small (60-watt or less) soldering iron. Replace with a 1 amp, 250 volt pigtail fuse, type 3AG or equivalent only.

Maintenance

Maintenance

PARTS LIST

Reference Symbol	Description	Simpson Part No.
R1	Resistor, 1138 ohms	1-113372
R2	Resistor, 110 ohms	1-113373
R3	Resistor, 21,850 ohms	1-113369
R4	Resistor, 117,700 ohms	1-113367
R5	Resistor, 238 ohms	1-115897
R6	Resistor, 37,500 ohms	1-113393
R7	Resistor, 200,000 ohms	1-113365
R8	Resistor, 800,000 ohms	1-113363
R9	Resistor, 3.75 megohms	1-115765
R10	Resistor, 45,000 ohms	1-114192
R12	Resistor, 150,000 ohms	1-113366
R13	Resistor, 1 megohm	1-113392
R14	Resistor, 4 megohms	1-113362
R15	Resistor, 15 megohms	1-115763
R16	Resistor, 11.2 ohms (bobbin)	10-805073
R17	Resistor, 0.452 ohm (bobbin)	10-805027
R18	Resistor, 22.5 ohms (bobbin)	0-008133
R19	Resistor, 2 ohms (bobbin)	0-008060
R20	Resistor, 80 megohms	1-113353
R21	Resistor, 20.2 megohms	1-116491
R22	Resistor, .025 Shunt Assy. 10 amp	0-007093
R25	Potentiometer, 10,000 ohms \pm 30%	1-115764
R26	Resistor, 7500 ohms	1-113370
R27	Rheostat, 5K ohms \pm 10%	1-116254
R28	Rheostat, 5K ohms \pm 10%	1-116254
R29	Resistor, 5000 ohms	1-113425

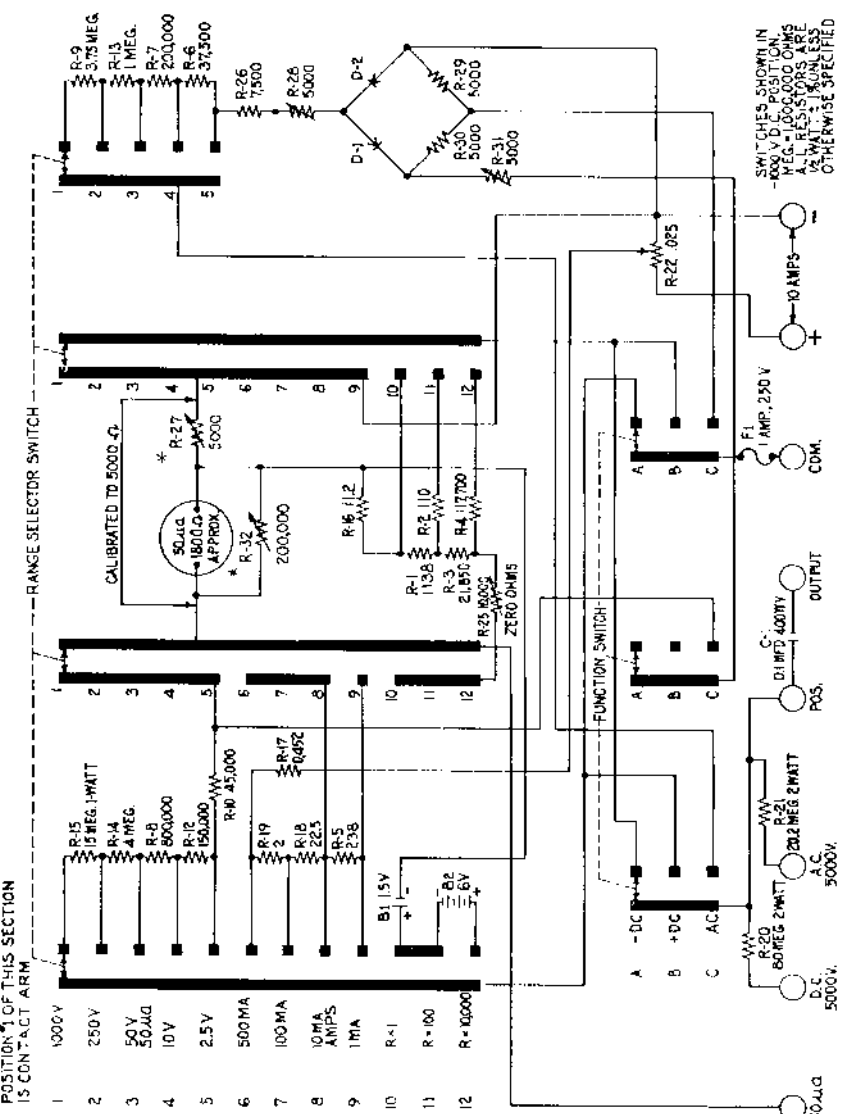

* R32 is adjusted for a circuit current of 50 microamperes, then R27 is adjusted for a circuit resistance of 5,000 ohms.

FIGURE 2. OVERALL SCHEMATIC, SIMPSON VOLT-OHM-MILLIAMMETER 260 SERIES 4 & SERIES 4M

Maintenance

Reference Symbol	Description	Simpson Part No.
R30	Resistor, 5000 ohms	1-113425
R31	Rheostat, 5K ohms $\pm 10\%$	1-116254
R32	Potentiometer, 200K $\Omega \pm 20\%$	1-110193
C1	Capacitor, 0.1 μf , 400 v.	1-113733
D1	Diode, Germanium	1-115970
D2	Diode, Germanium	1-115970
	Test lead set (one red and one black)	7500
	Phenolic case	3-320141
	Carrying handle	1-115316
	Knobs	
	For Function switch	1-115790
	For Range switch (less set screw)	3-260180
	For Zero Ohms Adjust	1-115789
F1	Fuse, 1 amp, 250 volt, pigtail type 3AG or equivalent	1-117702
260-4M	Meter Assembly	15-302260-4M
	Set Screw (for knob 3-260180)	1-114178
260-4	Meter Assembly	15-302260-4

SECTION IV APPLICATIONS

GENERAL

The Simpson Volt-Ohm-Milliammeter 260[®], Series 4, is designed to measure almost all characteristics of electrical and electronic circuits. It is the most versatile piece of test equipment which you can own.

In D.C. circuits, it will measure the voltage, the current, and the resistance. The measurements are made, through a very wide and common range, in terms of ordinary units for

Applications

all values. Although the upper limit for D.C. voltage with the 260[®], Series 4, is 5000 volts, Simpson makes accessory multiplier probes to extend the range to 25,000 and 50,000 volts! By way of contrast, direct currents as small as 1 microampere can be read on the 50 microampere D.C. range.

For A.C. voltage measurements, the values are shown in terms of either R.M.S. volts on the basis of full wave rectification, or of decibels. The decibel ranges are based on the common arbitrary zero level of 1 milliwatt in 600 ohms.

Both portions of mixed A.C. and D.C. voltages can be read with the 260[®], Series 4. The output circuit measures the A.C. portion, and the D.C. portion is indicated directly with the D.C. voltage circuit.

FORWARD AND REVERSE RECTIFIER RESISTANCES

The resistance of copper oxide, selenium, and crystal rectifiers can normally be measured in both directions. However, the resistance should be quite small in one direction (for forward polarity) and very large in the opposite direction. Use the 260[®], Series 4, ohmmeter circuit to determine that there is a large difference between the resistances in the two directions.

SIMPLE CAPACITOR CHECKS

The ohmmeter circuit of the 260[®], Series 4, can be used to identify good, open, and short conditions for many capacitors. Use the R x 10,000 range for best results.

A good capacitor will allow current to flow, deflecting the

Applications

meter pointer, while it is charging up to the applied voltage. This produces a swing on the meter, with a gradual return of the pointer to infinity at the left hand side of the scale. The greater the capacity, the more the pointer will swing and the longer it will take for it to return to infinity.

If the capacitor is open, there will be no pointer deflection at the beginning of this test. Note that very small capacitors will have only a very slight deflection and a rapid return to infinity. Watch the meter closely when you test small capacitors.

If the capacitor is shorted, the pointer will not return to infinity. So when the pointer remains deflected on the ohms scale, and does not return, even slowly, this probably indicates a short in the capacitor.

Always reconfirm the results of these simple tests with more conclusive test equipment, or by replacement checks.

ACCESSORY DC HIGH VOLTAGE PROBES

DC HIGH VOLTAGE TEST PROBES (20,000 OHMS PER VOLT)

PART NO. 0507	10,000 Volts DC
PART NO. 0508	25,000 Volts DC
PART NO. 0509	50,000 Volts DC

GENERAL DESCRIPTION

The DC high voltage probes extend the range of a 20,000 ohms per volt multimeter in a safe, convenient manner at nominal cost. Their primary purpose is the measurement of terminal potentials of very high voltage, very low power capacity direct current sources, example of which are anode supplies used in television receivers and other cathode ray tube type circuitry.

The probe body is made of high temperature polystyrene in order to provide high dielectric strength and low leakage. It contains a high megohm precision resistor.

A shielded cable and internal probe shield is used to protect the operator from any possible flash-over and to ground any electrostatic charges that might accumulate on the probe body.

The internal shield and cable shield are connected to the ground return lead by a flexible copper braid between the two elbow connectors. A 48 inch ground return lead with an insulated clip completes the test lead set. No additional wires are needed.

ELECTRICAL SPECIFICATIONS

These D.C. high voltage probes are designed for use with the Simpson Model 260^(®), Series 4 or any 20,000 ohms per volt tester having a 2.5 volt D.C. range and scale graduations from 0-10 or multiple thereof for the 10 KV probe, 0-25 or multiple thereof for the 25 KV probe, and 0-50 or multiple thereof for the 50 KV probe.

Accuracy:

Probe Resistance $\pm 2\%$.

High temperature polystyrene material was selected for the probe body because of its high dielectric strength, high resistivity and low moisture absorption, all of which are vitally important factors in high resistance and high voltage applications.

This material begins to soften at approximately 200 degrees and melts at approximately 300 degrees Fahrenheit. Caution should therefore be exercised when using the probe near components which operate at high temperatures, in order to prevent distortion or other damage to the probe body due to heat.

The DC high voltage test probes are available at your local electronics parts distributors.

NEW!
Simpson
MIDGETESTER
 ... SELF MODEL 355
 SHIELDED!

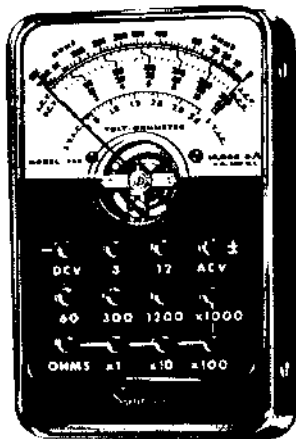
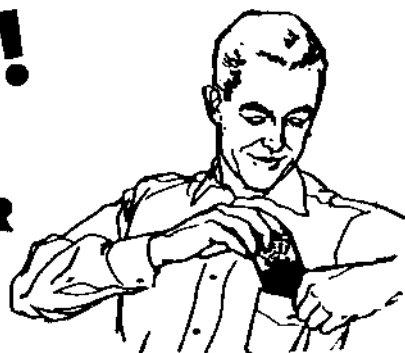

(not affected by steel-topped benches, heavy current carrying circuits, stray magnetic fields, etc.)

Here's the first practical shirt-pocket volt-ohmmeter commercially available. Although it measures *only* 2 3/4" x 4 1/2" x 1" over-all, it's a practical working instrument with ruggedness and accuracy of testers many times larger. Has a sensitivity of 10,000 ohms per volt on both AC and DC! Fourteen measurement ranges are available *five for AC voltages, five for DC voltages, and four for DC resistances.* A perfect instrument for all electrical and electronic servicemen.

RANGES, DC AND AC VOLTAGE: 3, 12, 60, 300, 1200.

DC RESISTANCES: 0-10K ohms (120 ohms center);
 0-100K ohms (1200 ohms center); 0-1 megohm
 (12K ohms center); 0-10 megohms (120K ohms center).

Size; 2 3/4" wide, 4 1/2" high, and 1" thick. Weight; 7 oz. **\$34⁹⁵**
 Model 355 with Leads, Operator's Manual.....
 Zipper Type Carrying Case No. 6355..... **\$3⁹⁵**

**SIMPSON WARRANTY REPAIR STATIONS
 AND PARTS DEPOTS**

- | | |
|--|---------------------------------------|
| **Arizona, Phoenix
Metercraft Inc.
3308 N. 24th St.
States: Arizona | Area Code 602
CRestwood 9-6249 |
| California, San Diego
Metermaster/San Diego, Inc.
5049 Weeks Avenue
San Diego Area | Area Code 714
276-5202 |
| California, Los Angeles
Quality Electric Company
3700 South Broadway
States: So. California below Fresno and Arizona | Area Code 213
ADams 2-4201 |
| California, San Francisco
Pacific Electrical Instrument Lab.
111 Main Street
States: No. California above Fresno and Nevada | Area Code 415
Garfield 1-7185 |
| **Canada
Bach-Simpson Ltd.
1255 Brydges Street
P.O. Box 484
London, Ontario Canada | Area Code 519
GLadstone 1-9490 |
| Colorado, Denver
Meter-Master Instrument Service
2145 S. Kalamath Street
States: Wyoming, Colo., and New Mexico | Area Code 303
934-4601
934-4069 |
| Connecticut, New Haven
Kaufman Instrument Labs Inc.
810 Dixwell Avenue
States: Connecticut | Area Code 203
SPruce 6-7201 |
| Florida, Orlando
Electro Tech Inc.
Florida Division
307-27th Street
States: Florida | Area Code 305
GArden 3-5589 |
| Georgia, Atlanta
Electro-Tech Inc.
690 Murphy Ave. S.W.
States: Alabama, Georgia and Tenn. | Area Code 404
758-7205 |

****Illinois, Chicago**
 Simpson Electric Company
 5200 W. Kinzie Street
 Area Code 312
 ESTebrook 9-1121

***Illinois, Chicago**
 Pacific Indicator Company
 5217 W. Madison Street
 States: Chicago, Wisconsin and Indiana
 Area Code 312
 COLumbus 1-1330

****Kansas, Shawnee Mission**
 Sturtz Instrument Co.
 4705 Mission Road
 States: Kansas
 Area Code 913
 SKYline 1-4711

Louisiana, New Orleans
 Industrial Instrument Works
 3328 Magazine Street
 States: Arkansas, Mississippi and Louisiana
 Area Code 504
 TWINbrook 5-5621

Massachusetts, Cambridge
 Alvin S. Mancib
 363 Walden Street
 States: Vermont, New Hampshire, Massachusetts
 Rhode Island and Maine
 Area Code 617
 UNiversity 4-2494

Michigan, Detroit
 Ram Meter Inc.
 1100 Hilton Road Ferndale
 States: Michigan
 Area Code 313
 LINcoln 7-1000

Minnesota, Minneapolis
 Instrumentation Services Inc.
 917 Plymouth Avenue N.
 States: Minnesota, North, South Dakota and Nebraska
 Area Code 612
 JA 1-8803

Missouri, St. Louis
 Scherrer Instruments
 5449 Delmar Blvd.
 States: Illinois below Peoria, Iowa, Missouri
 Area Code 314
 FOREst 7-9800

New Jersey, Riverdale
 A & M Instrument Service, Inc.
 11 Hamburg Turnpike
 States: N. Jersey
 Area Code 609
 MARKET 4-7757

****New Mexico, Albuquerque 87108**
 Western Instrument Lab. Inc.
 4401 Coal Avenue S.E.
 States: New Mexico
 Area Code 505
 265-8494

New York, Buffalo
 Electrical Instrument Labs.
 932 Hertel Avenue
 States: New York State Except Met. New York
 Area Code 716
 EXport 2-2726

New York, Great Neck, Long Island
 Simpson Instrument Sales & Service, Inc.
 130 Cutter Mill Road
 States: Met. New York
 Area Code 212
 MURray Hill 3-0674
 Area Code 516
 HUNter 2-3103

New York, Long Island City
 A & M Instrument Inc.
 48-01 31st Avenue
 States: Met. New York
 Area Code 212
 RAVenswood 6-4343

****New York, Syracuse**
 Syracuse Instrument Lab.
 4895 South Avenue Box 96
 Area Code 315
 HYatt 2-1651

****New York, Vestal**
 Compton Industries Inc.
 333 Vestal Parkway East
 P.O. Box 351
 States: Up-State New York
 Area Code 607
 PI 8-3349

North Carolina, Charlotte
 Electro-Tech Inc.
 3107 Cullman Avenue (Carolina Division)
 States: North and South Carolina
 Area Code 704
 333-0326

Ohio, Cleveland
 Weschler Electric Company
 4250 W. 130th Street
 States: Ohio and Kentucky
 Area Code 216
 CLearwater 1-4609

****Ohio, Cleveland**
 Pioneer Electronic Supply
 Div. of Pioneer Standard Electronic
 Corp.
 5403 Prospect Avenue
 Area Code 216
 432-0010

** Ohio, Dayton SREPCO Electronics Div. of Pioneer Standard Electronic Corp. 314 Leo Street	Area Code 513 BALdwin 4-3871
**Oklahoma, Tulsa Tri-State Instrument Lab. 3244 East 15th Street States: Oklahoma	Area Code 918 WE 6-0489
**Oregon, Portland The Instrument Laboratory 1910 N. Killingsworth St. States: Oregon	Area Code 503 BELmont 4-6683
Pennsylvania, Philadelphia Sunshine Scientific Instrument 1810 Grant Avenue States: Penn., Md., New Jersey below Trenton, Delaware	Area Code 215 ORChard 3-5600
***Texas, Dallas Ultra Instrument Laboratories 3515 Swiss Avenue, Suite 117 States: Oklahoma, Texas	Area Code 214 TAYlor 6-6395 6-6396
Utah, Salt Lake City Stabro Laboratories, Inc. 23 Kensington Avenue States: Utah, Southern Idaho	Area Code 801 IN 7-8011
Virginia, Falls Church United Instrument Lab. Inc. 102 Jefferson St. States: West Virginia, Virginia.	Area Code 703 JEfferson 2-4123
**Washington, D. C. Electronic Wholesalers, Inc. 2345 Sherman Avenue N. W. Washington, D. C.	Phone: IUU 3-5200
Washington, Seattle The Instrument Lab. Inc. 934 Elliott Avenue West States: Oregon, Washington Idaho and Montana	Area Code 206 ATwater 3-5850

* Parts Depots only; no repairs.
 ** Repair Stations only - no resale of parts.
 (All other stations repair instruments and sell repair parts)
 *** Parts Sales - Texas, Oklahoma
 Repair -- Texas only.

WARRANTY

SIMPSON ELECTRIC COMPANY warrants each instrument and other articles of equipment manufactured by it to be free from defects in material and workmanship under normal use and service, its obligation under this warranty being limited to making good at its factory any instrument or other article of equipment which shall within 90 days after delivery of such instrument or other article of equipment to the original purchaser be returned intact to it, or to one of its authorized service stations, with transportation charges prepaid, and which its examination shall disclose to its satisfaction to have been thus defective; this warranty being expressly in lieu of all other warranties expressed or implied and of all other obligations or liabilities on its part, and SIMPSON ELECTRIC COMPANY neither assumes nor authorizes any other persons to assume for it any other liability in connection with the sale of its products.

This warranty shall not apply to any instrument or other article of equipment which shall have been repaired or altered outside the SIMPSON ELECTRIC COMPANY factory or authorized service stations, nor which has been subject to misuse, negligence or accident, incorrect wiring by others, or installation or use not in accord with instructions furnished by the manufacturer.

EXTRA 260® SERIES 4 & 4M ACCESSORIES AVAILABLE D.C. HIGH VOLTAGE PROBES

10,000 VOLTS — PART No. 0507	\$10.20
25,000 VOLTS — PART No. 0508	\$11.50
50,000 VOLTS — PART No. 0509	\$12.50

CARRYING CASES

LEATHER CARRYING CASE FOR 260® SERIES 4 & 4M (No. 1818)	\$8.50
EVEREADY VINYL PLASTIC CARRYING CASE FOR 260® SERIES 4 & 4M (No. 4236)	\$9.75

Simpson ELECTRIC COMPANY

5200 Kinzie St., Chicago 44, Illinois • Phone: ESTebrook 9-1121 • Long Distance Dial 312
 In Canada: Bach-Simpson, Ltd., London, Ontario



LAC DU FLAMBEAU PLANT
WISCONSIN



LAKE STREET PLANT
CHICAGO



KINZIE STREET PLANT
CHICAGO



AURORA PLANT
AURORA, ILL.