

new VOM's

from

Simpson

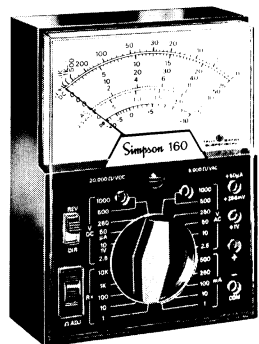

160 Handi-VOM®

Just 3⁵/₁₆" Wide . . .
with Full-Size VOM Features

- 20,000 Ω VDC . . . 5,000 Ω VAC
- ±2% DC . . . ±3% AC
- 5 Resistance Ranges . . . Plus a 0-250 DC Millivolt Range

313 Solid-State VOM

VTVM Features . . . VOM Conveniences

- Uses a single 9-volt battery
- 10 Meg Ω DC . . . 11 Meg Ω AC
- Large 7" scale

Write for bulletin 2078

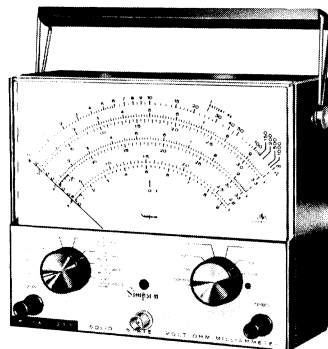

Simpson has over 1,400 stock sizes and types of panel meters, too!

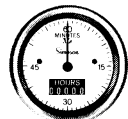

Write for bulletin 2079

OPERATOR'S MANUAL

VOLT-OHM-MILLIAMMETER

260[®], SERIES 5P

Courtesy of Simpson260.com

With Thanks To: Fred Scoles

SIMPSON ELECTRIC COMPANY

5200 W. Kinzie St., Chicago, Illinois 60644
Area Code 312, Telephone 379-1121
In Canada, Bach-Simpson, Ltd., London, Ontario

Copyright, 1968, Simpson Electric Co.
10-68 UMO B & L

Printed in U.S.A.
5-110196

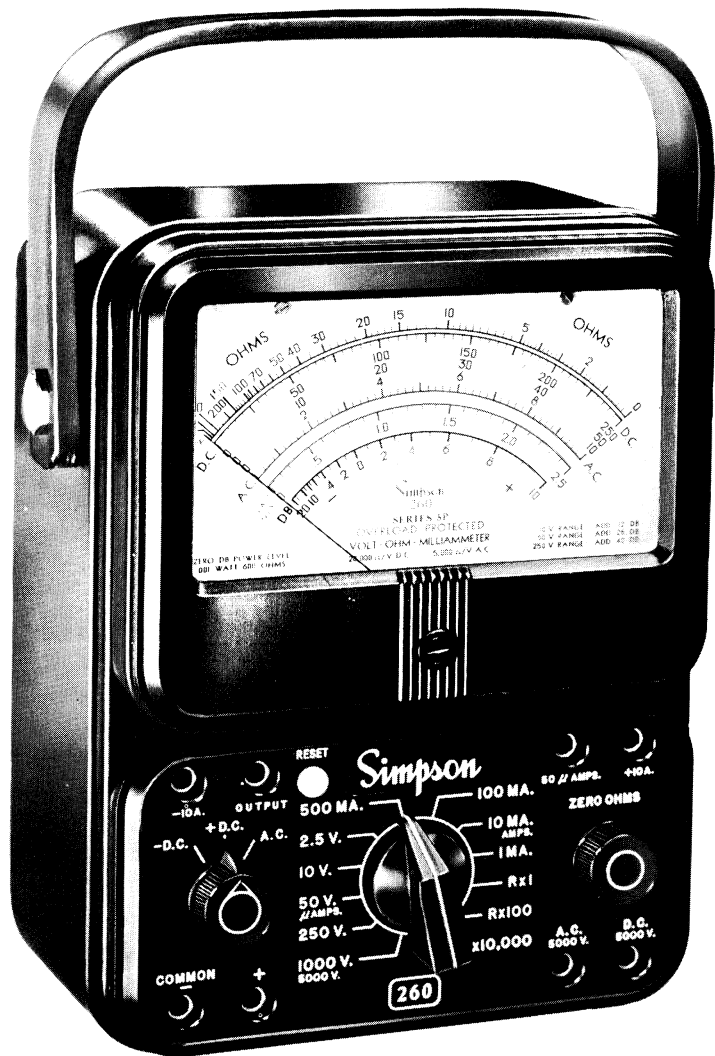

FIGURE 1 SIMPSON 260[®], SERIES 5P OVERLOAD PROTECTED
VOLT-OHM-MILLIAMMETER.

TABLE OF CONTENTS

	Page
Specifications	4
General Description	5
Operating Instructions	11
Measuring D.C. Voltages	13
Measuring A.C. Voltages	16
Measuring Output Voltages	18
Measuring Decibels	19
Measuring Resistances	20
Measuring Direct Currents	23
Maintenance	26
Schematic	31
Parts List	32
Applications	33
Accessory D.C. High - Voltage Probes	36

SPECIFICATIONS

SECTION I

D.C. VOLTAGE

	Accuracy in % of F.S.
Sensitivity; 20,000 ohms per volt	
0-250 millivolts	2
0-2.5-10-50-250-1000 volts	2
0-5000 volts	3

A.C. VOLTAGE

Sensitivity; 5,000 ohms per volt	
0-2.5-10-50-250-1000 volts	3
0-5000 volts	4

DIRECT CURRENT

0-50 microamperes	1.5
0-1-10-100-500 milliamperes	2
0-10 amperes	2

D.C. RESISTANCE

	Accuracy in degrees of arc
Rx1 for 0-2000 ohms (12 ohms center)	2.5
Rx100 for 0-200,000 ohms (1200 ohms center)	2.0
Rx10,000 for 0-20 megohms (120,000 ohms center)	2.0

A.F. OUTPUT VOLTAGE

With 0.1 uf internal series capacitor.
0-2.5-10-50-250 volts

VOLUME LEVEL IN DECIBELS

With zero DB equal to 1 milliwatt across a 600 ohm line.
-20 to +50DB in 4 ranges

SPECIFICATIONS

FREQUENCY RESPONSE

2.5 volt range	5% from 30Hz to 1MC 100KHz 3% from 30Hz to 750KC 80KHz
10 volt range	5% from 30Hz to 400KC 80KHz 3% from 30Hz to 200KC 70KHz
50 volt range	5% from 30Hz to 300KC 80KHz 3% from 30Hz to 200KC 50KHz
250 volt range	5% from 30Hz to 100KC 35KHz 3% from 30Hz to 80KC 30KHz

OUTPUT

The frequency response of the output ranges are essentially the same as the A.C. voltage ranges except that a small error is introduced at the low frequency end due to the capacitive reactance of the series capacitor at those frequencies.

BATTERIES

One 1.5 volt (Eveready #950 or equivalent) and one 15 volt (Eveready #417 or equivalent).

SIZE

5¼" x 7" x 3-1/8".

WEIGHT

3 pounds

GENERAL DESCRIPTION

The Simpson 260® Series 5P is an accurate, compact, and easy to operate Volt-Ohm-Milliammeter. It is extremely rugged and incorporates a unique overload protection circuit to prevent meter or tester damage in the event of accidental overload. Its primary use is the measurement of electrical

GENERAL DESCRIPTIONS

characteristics of circuits and circuit components. Accurate quantity measurements of D.C. and A.C. voltages, direct currents, resistances, decibels, and output voltages can be made.

To complement the circuit accuracy, this tester features the new Simpson taut-band, annular movement. The annular movement provides self-shielding, and the taut band suspension provides a high degree of repeatability that is greatly resistant to damage by shock or vibration.

A special calibration circuit is used to increase the initial accuracy of the tester and to facilitate recalibration in the event that this should ever be necessary.

The 260-5P uses the most modern components and circuit techniques. Assembly is done by well trained personnel using quality material and modern equipment. This combination of design, materials, and skillful assembly results in a unit that will take considerable abuse and still provide accurate indication. If it is kept clean and is not subjected to extreme shock or continuous vibration, the 260-5P will give many years of trouble free service.

OVERLOAD PROTECTION

With the exception of the 10 ampere D.C., 1000 volt and 5000 volt A.C. and D.C. ranges, all ranges are protected against inadvertent overload damage by a unique protection system. The sensing circuit is completely electronic and does not depend on unreliable mechanical means for act-

GENERAL DESCRIPTIONS

uation. Instead, a highly sensitive semiconductor senses the voltage drop across the meter circuit and actuates a relay when the voltage reaches a predetermined level. Power for the relay is supplied by the same battery that is used for the Rx10,000 resistance range. Sensing of the voltage drop across the meter is done by means of a bridge network, so that overload protection is provided regardless of the polarity. The protection relay operates at a uniform percentage of overload since the meter circuit is common to all ranges.

Since the same battery is used for the high ohms range and the protection circuit, the tester is designed so that the protection circuit will function normally as long as the high ohms range can be set to zero. It is recommended that the Rx10,000 range be checked each time that the tester is used to be certain that the proper zero adjustment is possible.

To supplement protection of the meter a diode network is connected across the movement to by-pass any transient overloads.

FUSE PROTECTION

As additional protection against possible damage to the tester, a 10 ampere fuse is connected in series with the relay contacts in the input circuit. Since high currents may be encountered if the Rx1 or current ranges are overloaded, it is possible that this fuse may blow in addition to the opening of the relay contacts. If the fuse blows, the tester will be inoperative.

GENERAL DESCRIPTIONS

FRONT PANEL

The instrument has a large easy-to-read $4\frac{1}{2}$ " meter at the top of the front panel. Below the meter are three operating controls, eight circuit jacks, and the reset button. All switch positions, circuit jacks, and reset button are identified with engraved white lettering on a black background to insure long lasting, easy readability.

RANGE SWITCH

The range switch, in the center of the lower part of the front panel, has 12 positions. It may be turned in either direction to obtain any desired range and circuit position. There are six voltage ranges for D.C. and six for A.C., six ranges for direct current, and three resistance ranges.

FUNCTION SWITCH

The function switch is located at the left hand side of the lower part of the front panel. It has three positions: -D.C., +D.C., and A.C. When direct current, D.C. voltage, or resistance is to be measured, the function switch may be set at -D.C. or +D.C., depending on the polarity of current or voltage. Reversing the test lead connections without removing them from the circuit under test is accomplished by use of the function switch.

ZERO OHMS

The control at the lower right on the panel is marked ZERO OHMS. This variable resistance in the ohmmeter circuit will be used to compensate for the aging of the internal batteries. Use it to adjust the meter indication to zero (at the right end of the scale) with the test leads shorted together whenever the ohmmeter circuit is used.

GENERAL DESCRIPTIONS

CIRCUIT JACKS

There are eight jacks, two being located in each corner of the front panel. These are the connection points for the test leads. Plug the prods of the test leads into the proper jacks to obtain the circuit and range desired for each application.

At the lower left are COMMON - and + jacks. These are the jacks that will be used most. Connect the black test lead to COMMON - for all circuits and ranges except 10 amperes D.C. Connect the red test lead to the + jack for all circuits and ranges except those designated by the other circuit jacks.

Across the top of the panel are jacks marked - 10 A., OUTPUT, 50 uAMPS, and + 10 A. For all audio frequency output voltage ranges, use the red test lead connected to the OUTPUT jack. For the 50 microampere or 250 millivolt D.C. range, use the red test lead connected to the 50 uAMPS jack. For the 10 ampere D.C. range, use the black test lead in the - 10 A. jack and the red test lead in the + 10 A. jack.

RESETTING THE TESTER AFTER AN OVERLOAD

The reset button is made of a non-conducting material to insure protection against accidental shock and is located just to the right of the "output" jacks on the front panel. When an overload of sufficient magnitude to trigger the protection circuit is applied to the tester, the reset button will pop up and extend approximately $\frac{3}{16}$ " above the surface of the front panel.

GENERAL DESCRIPTIONS

To reset the tester for normal operation first remove the overload, then press the reset button all the way down and release it. The tester is now ready for normal operation.

If the overload has inadvertently been left connected to the tester, following the reset procedure as outlined above or holding down the reset button will not reconnect the tester circuitry. This "fool proof" feature makes it almost impossible to damage the 260-5P under usual overload conditions.

PHENOLIC CASE

The Simpson 260, Series 5P is housed in a black phenolic case. It is molded with heavy reinforced walls for maximum durability. All the component parts are attached or mounted to the front panel: the entire instrument slips into and out of the case in one piece.

PRINTED CIRCUIT

Conforming to the latest engineering developments, almost all the component parts are mounted on a printed circuit. This simplifies assembly, reduces maintenance, and extends the useful life of the instrument.

ADJUST-A-VUE HANDLE

The comfortable handle is attached on each side of the instrument case. The handle may be used to support the instrument in a convenient sloping position for easy viewing on the bench top. Of course, the 260 can also be placed in either a vertical or horizontal position.

GENERAL DESCRIPTIONS

TEST LEADS

Each 260, is furnished with one pair of four-foot test leads. One lead is black and the other red for easy polarity identification. The wire is very finely stranded and extra-flexible. Its insulation is a special high-grade rubber which has far more insulation strength than the largest voltages to which your instrument will ever be subjected.

TEST LEAD INSPECTION

Periodic inspection of the test leads is recommended to detect cuts, burns or other damage that could reduce the insulation strength of the leads. When replacement is indicated, ask your local distributor for catalog number 7500.

SECTION II

OPERATING INSTRUCTIONS

CAUTION

When making voltage or current measurements, as a personal protection, form the habit of turning off all power to the circuit under test. Connect the test leads at the desired points in the circuit. Then turn on the power while taking readings. Turn off the circuit.

OPERATING INSTRUCTIONS

ADJUST POINTER FOR ZERO

Before any measurements are made, check to see that the pointer indicates zero when the meter is in its operating position. If the pointer is off zero, adjust the screw located in the phenolic case below the center of the meter scale, as shown in Figure 1. Use a small screwdriver to turn this screw slowly clockwise or counterclockwise until the pointer is exactly over the zero mark at the left side of the scale.

CHECK OVERLOAD BATTERY

After the pointer has been adjusted for zero it is imperative that the battery used in the overload protection circuit be checked for proper voltage. To check this battery proceed as follows:

1. Set the range switch at the Rx10,000 position and the function switch at either -D.C. or +D.C.
2. Connect the black test lead in the COMMON - jack and the red test in the + jack.
3. Clip the contact end of the test leads together to short out the resistance circuit.
4. Observe the meter indication. It should read 0 on the right hand end of the OHMS arc, which is at the top of the dial.
5. If the pointer does not read 0, rotate the ZERO OHMS knob until it does. If you cannot bring the pointer far enough to read 0, the 15 volt battery must be replaced before proceeding further.

The overload protection circuit will not function properly if the battery voltage is below the minimum level needed to zero the Rx10,000 range.

OPERATING INSTRUCTIONS

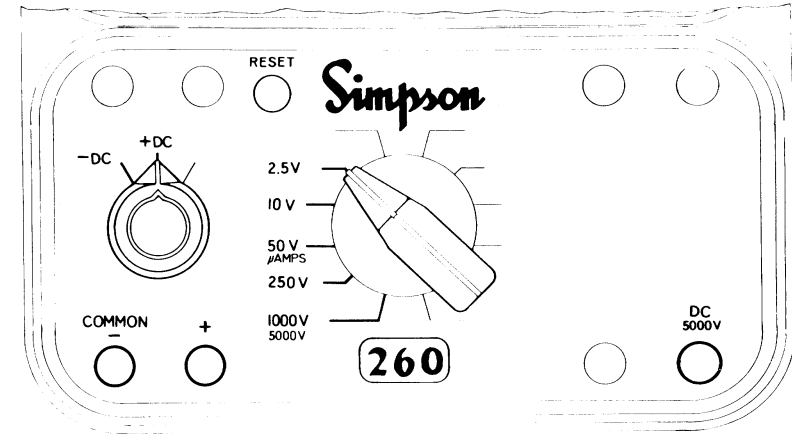

CONTACTS AND SWITCH POSITIONS FOR D.C. VOLTS.

MEASURING D.C. VOLTAGES 0-250 MILLIVOLT RANGE ONLY

1. Set the function switch at +D.C.
2. Connect the black test lead in the COMMON- jack and the red test lead in the 50 uAMPS jack.
3. Set the range switch at 50 uAMPS (common position with 50 V.).
4. Connect the black test lead to the negative side of the circuit to be measured, and the red test lead to the positive side of the circuit.
5. Read the voltage on the black arc marked D.C., and use the figures marked 0-250; read directly in millivolts.

MEASURING D.C. VOLTAGES TO 1000 VOLTS

1. Set the function switch on the left hand side of the front panel at +D.C.

OPERATING INSTRUCTIONS

2. Plug the black test lead into the COMMON-jack and the red test lead into the +jack.
3. Set the range selector switch in any of the five voltage range positions. These are marked 2.5 V., 10 V., 50 V., 250 V., and 1000 V. When in doubt as to the voltage present, always use the highest voltage range as a protection to the instrument. Observe the meter reading. If the voltage is within a lower range, the switch may be set for the lower range to obtain a more accurate reading.
4. Connect the black test lead to the negative side of the circuit to be measured and the red test lead to the positive side of the circuit.
5. Turn on the power in the circuit to be tested. If the pointer deflects to the left of zero, the anticipated polarity is opposite the actual circuit polarity. Turn off the power in the circuit which is being tested. Set the function switch at -D.C., and turn on the power again. This will correct the polarity as applied to the meter.
6. Read the voltage on the black arc marked D.C. which is second from the top of the dial.
 - For the 2.5 V. range use the 0-250 figures and divide by 100.
 - For the 10 V., 50 V., and 250 V. ranges read the figures directly on the scale.
 - For the 1000 V. range use the 0 - 10 figures and multiply by 100.
7. Turn off the power in the circuit which is being measured before disconnecting meter leads.

OPERATING INSTRUCTIONS

MEASURING D.C. VOLTAGES TO 5000 VOLTS

WARNING

Be extremely careful when working in high voltage circuits. Do not touch the meter or test leads while power is on in the circuit being measured.

1. Set the function switch at +D.C.
2. Set the range selector switch at 5000 V.
3. Connect the black test lead into the COMMON - jack and the red test lead into the D.C. 5000 V. jack.
4. Be sure power is off in the circuit to be measured and all capacitors have been discharged: connect the black test lead to the negative side of the circuit to be measured and the red test lead to the positive side of the circuit.
5. Turn on the power in the circuit. Do not touch the meter or test leads. If the pointer deflects to the left side of zero, the anticipated polarity is opposite the actual circuit polarity. Turn off the power in the circuit being tested. Set the function switch at -D.C., and turn on the power again. This will correct the polarity as applied to the meter.
6. Read the voltage using the 0-50 figures on the black arc which is second from the top of the scale. Multiply the reading by 100.
7. Turn off the power before disconnecting the test leads.

NOTE: To measure higher D.C. Voltage, see section IV for high voltage accessory probes.

OPERATING INSTRUCTIONS

MEASURING A.C. VOLTAGES TO 1000 VOLTS

The 260 measures A.C. voltage in terms of the R.M.S. value of a sine wave. This is accomplished by using two germanium diodes in a modified full wave bridge circuit.

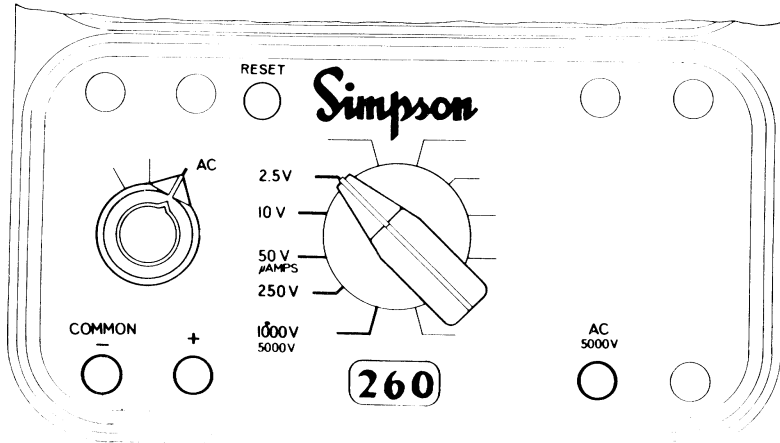

CONTACTS AND SWITCH POSITIONS FOR A.C. VOLTS.

1. Set the function switch at A.C.
2. Set the range selector switch in any of the five voltage range positions, marked 2.5 V., 10 V., 50 V., 250 V., and 1000 V. When in doubt as to the voltage present, always use the highest voltage range as a protection to the instrument. Observe the meter reading. If the voltage is within a lower range, the switch may be set for the lower range to obtain a more accurate reading.
3. Plug the black test lead into the COMMON - jack and the red test lead into the + jack.

OPERATING INSTRUCTIONS

4. Be sure power is turned off in the circuit to be measured and connect the test leads across the voltage source.
5. Turn on the power in the circuit to be measured.
For the 0-2.5 V. range read the value directly on the the special arc marked 2.5 V.A.C. ONLY.

For the 10 V., 50 V., and 250 V. ranges read the red arc marked A.C. and use the black figures immediately above the arc.
For the 1000 V. range read the red arc marked A.C. Use the 0-10 figures and multiply by 100.
6. Turn off the power in the circuit before disconnecting the leads.

MEASURING A.C. VOLTAGE TO 5000 VOLTS

WARNING

Be extremely careful when working in high voltage circuits. Do not touch the meter or test leads while power is on in the circuit being measured.

1. Set the function switch at A.C.
2. Set the range selector switch at 5000 V.
3. Connect the black test lead into the COMMON - jack and the red test lead into the A.C. 5000 V. jack.
4. Be sure the power is off in the circuit to be measured and that all its capacitors have been discharged. Connect the test leads into the circuit.
5. Turn on the power in the circuit to be measured. Do not touch the meter or test leads.
6. Read the voltage on the red arc marked A.C. Use the 0-50 figures and multiply by 100.
7. Turn off the power before disconnecting the test leads.

OPERATING INSTRUCTIONS

MEASURING OUTPUT VOLTAGES

An output voltage is the A.C. component only, when there is a mixture of A.C. and D.C. voltages. This occurs mostly in amplifier circuits.

The 260[®] has a capacitor in series with the OUTPUT jack. This blocks the D.C. component of the current in the measuring circuit, but allows the A.C. or desired component to pass on to the meter circuit. The blocking capacitor placed in series with the A.C. voltage measuring circuits alters the low frequency A.C. response. See page 5.

1. Set the function switch on the left hand side of the front panel at A.C.

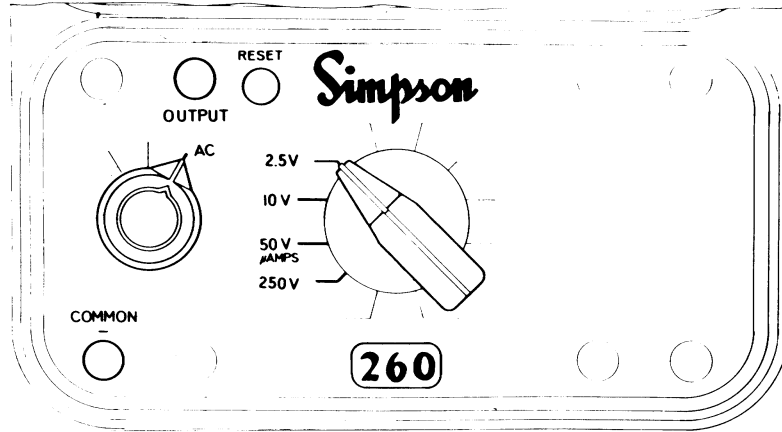

CONTACTS AND SWITCH POSITIONS FOR OUTPUT

OPERATING INSTRUCTIONS

2. Connect the black test lead in the COMMON – jack and the red test lead in the OUTPUT jack.
3. Set the range selector switch at the desired range position. These are marked 2.5 V., 10V., 50 V., and 250 V.
4. Connect the black test lead to the grounded side of the circuit to be measured and the red test lead to the “hot” side.
5. Turn on the power in the circuit. Read the output voltage on the A.C. voltage arcs of the dial.
For the 0–2.5 V. range read the value directly on the special arc marked 2.5 V.A.C. ONLY.
For the 10 V., 50 V., and 250 V. ranges use the red arc marked A.C. and read the black figures immediately above the arc.
6. Turn off the power in the circuit before disconnecting the leads.

MEASURING DECIBELS

For some applications, output voltages and audio frequency voltages are frequently measured in terms of decibels. The decibel scale (DB), at the bottom of the dial, is numbered from –20 through 0 to +10.

To measure decibels, read the DB arc after proceeding according to instructions for A.C.

The DB readings obtained will be correct on an absolute scale if you are using a 0 DB power level of .001 watt in 600 ohms, and if the voltage which you read was measured across 600 ohms.

OPERATING INSTRUCTIONS

To obtain absolute DB values across 600 ohms:

For the 10 V. range read the DB arc and add +12 DB to the reading.

For the 50 V. range read the DB arc and add +26 DB to the reading.

For the 250 V. range read the DB arc and add +40 DB to the reading.

If the reference level is 0 DB = .006 watt in 500 ohms, subtract (+) 7 DB from the reading to obtain the absolute value of decibels.

MEASURING RESISTANCES

When resistances are measured, the batteries inside the case furnish power for the circuit. Since the batteries are subject to deterioration over long periods of time, there is a compensating circuit in the ohmmeter to correct for the normal variations in the battery voltage and resistance.

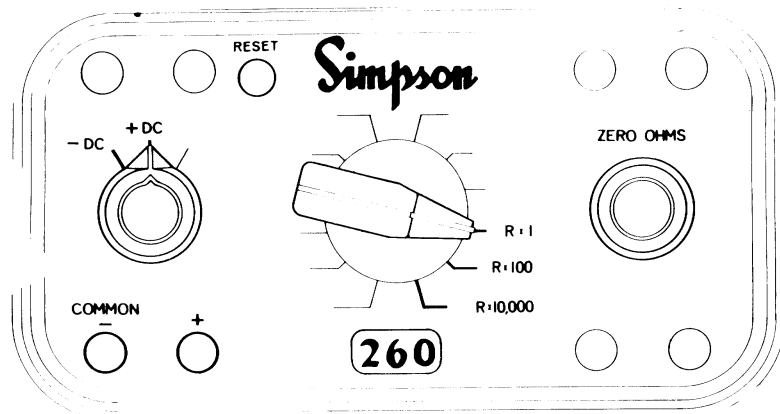

CONTACTS AND SWITCH POSITIONS FOR RESISTANCES.

OPERATING INSTRUCTIONS

Each time you use the ohmmeter circuit, check the zero indication on the meter before you measure any resistance. Check and adjust it each time you switch to a different range. To set the ZERO OHMS control, proceed as follows:

1. Set the range switch at one of the resistance range positions and the function switch at either -D.C. or +D.C.
2. Connect the black test lead in the COMMON-jack and the red test lead in the + jack.
3. Clip the contact end of the test leads together to short out the resistance circuit.
4. Observe the meter indication. It should read 0 on the right hand end of the OHMS arc, which is at the top of the dial.
5. If the pointer does not read 0, rotate the ZERO OHMS knob until it does. If you cannot bring the pointer far enough to read 0, one or more batteries need to be replaced.
6. When the pointer shows zero, unclip the shorted test leads; the ohmmeter circuit is now ready to use.

To measure resistance, proceed as follows:

1. Set the range switch in one of the resistance range positions.
Use R x 1 for resistance readings from 0 to 200 ohms.
Use R x 100 for resistance readings from 200 to 20,000 ohms.

OPERATING INSTRUCTIONS

Use R x 10,000 for resistance readings above 20,000 ohms.

2. Set the function switch at either -D.C. or +D.C.
3. Connect the black test lead in the COMMON - jack and the red test lead in the + jack.
4. Short the test leads together and adjust for zero ohms (see instructions above).
5. Separate the test leads and connect them across the resistance which is to be measured. If there is a "forward" and "backward" resistance such as in rectifiers, switch back and forth between the two D.C. positions of the function switch to reverse this polarity.

NOTE

The resistance of such rectifiers will measure different values on different resistance ranges of the 260. Thus, a crystal diode which measures 80 ohms, for example, on the R x 1 range may measure 300 ohms on the R x 100 range. This is normal, and is a result of the diode characteristic. The difference in values does not indicate any fault in the ohmmeter.

6. Read the indication on the OHMS arc at the top of the dial. Note that this arc reads from right to left for increasing values.
7. Multiply the reading by the multiplier factor at the switch position for the resistance value in ohms. "K" on the dial stands for "thousand".

OPERATING INSTRUCTIONS

MEASURING DIRECT CURRENTS, 0 TO 50 MICROAMPERES

CAUTION

Never connect the test leads directly across any voltage when the 260, Series 5P is used as a current meter.

Always connect the meter in series with the load across the voltage source.

1. Set the function switch at +D.C.
2. Connect the black test lead in the COMMON - jack and the red test lead in the 50 uAMPS jack.
3. Set the range switch at 50 uAMPS (common position with 50 V.).
4. Open the circuit in which the current is to be measured. Connect the meter in series with the circuit. Connect the red test lead toward the positive side, and the black test lead toward the negative side.

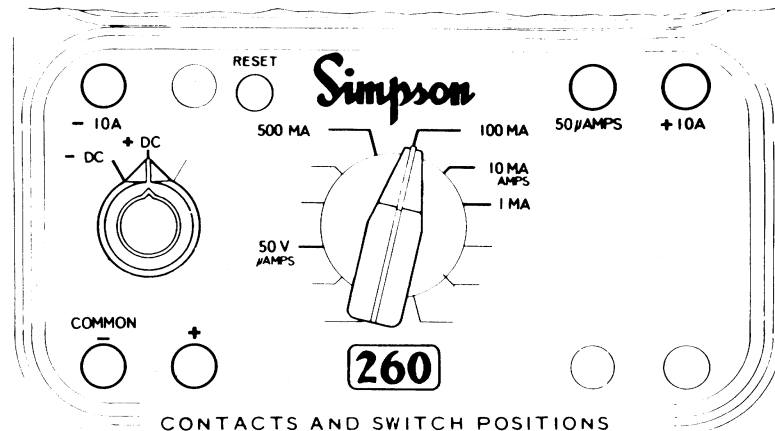

CONTACTS AND SWITCH POSITIONS
FOR DIRECT CURRENTS.

OPERATING INSTRUCTIONS

5. Turn on the power in the circuit which is to be measured. Observe the meter. If the pointer is deflected to the left, the current polarity is opposite to that which was anticipated. Turn off the power and reverse leads.
6. Read the current directly on the black D.C. arc. Use the 0 – 50 figures. The current value is shown in micro-amperes.
7. Turn off the circuit power. Remove the test leads and restore the circuit continuity.

MEASURING DIRECT CURRENTS, 0 TO 500 MILLIAMPERES

1. Set the function switch at +D.C.
2. Connect the black test lead in the COMMON – jack and the red test lead in the + jack.
3. Set the range switch in any of the four range positions required. These are marked 1 MA., 10 MA., 100 MA., and 500 MA.
4. Open the circuit which is to be measured. Connect the meter in series with the circuit. Connect the red test lead toward the positive side and the black test lead toward the negative side.
5. Turn on the power in the circuit which is to be measured. Observe the meter. If the pointer is deflected to the left, the current polarity is opposite to that which was anticipated. Turn off the power, set the function switch – D.C., and then turn on the power again.

OPERATING INSTRUCTIONS

6. Read the current directly on the black D.C. arc.
For the 1 MA. range use the 0 – 10 figures and divide by 10.
For the 10 MA. range use the 0 – 10 figures directly.
For the 100 MA. range read the 0 – 10 figures and multiply by 10.
For the 500 MA. range read the 0 – 50 figures and multiply by 10.
The current values are in milliamperes.
7. Turn off the circuit power. Remove the test leads and restore circuit continuity.

MEASURING DIRECT CURRENTS, 0 TO 10 AMPERES

1. Connect the black test lead in the – 10 A. jack and the red test lead in the +10 A. jack.
2. Set the range selector switch at 10 AMPS (common with 10 MA.).
3. Open the circuit which is to be measured. Connect the meter in series with the circuit. Connect the red test lead toward the positive side and the black test lead toward the negative side.
4. Turn on the power in the circuit which is to be measured. Observe the meter. If the pointer is deflected to the left, the current polarity is opposite to that which was anticipated. Turn off the power, reverse the test lead connections, and turn on the power again.

NOTE

The function switch has no effect on polarity for the 10 AMP range.

OPERATING INSTRUCTIONS

5. Read the current directly on the black D.C. arc. Use the 0 – 10 figures. The current values are in amperes.
6. Turn off the circuit power. Remove the test leads and restore circuit continuity.

SECTION III

MAINTENANCE

HOW TO OPEN THE CASE

The case of the 260, Series 5P has been designed to provide easy and quick access to the inside for all necessary adjustment and replacement of parts. Use a 1/4-inch screwdriver to remove the four screws through the back of the case. Then slip the entire front panel straight forward out of the case. The meter, the front panel, the printed circuit, and the batteries are all attached together and will come out as a unit.

BATTERY REPLACEMENT

There are two batteries inside the case of the tester. They are used to supply power for resistance measurements and the overload relay. One is a large size 1.5 volt flashlight cell, and the other is a "featherweight" 15 volt "B" battery. When it is no longer possible to bring the pointer to 0 for the Rx1 and Rx100 ranges (see ZERO OHMS page 8). Replace the 1.5 volt battery with a fresh one. When it is no longer possible to bring the pointer to 0 on the Rx10,000 range, replace the 15 volt battery with a fresh one. This will restore operation of the ohmmeter circuit.

Maintenance

NOTE: When batteries reach the end of their useful life, they should be replaced promptly. Failure to do so may result in extensive damage to your 260, Series 5P due to battery leakage, even though the battery may be advertised as "Leakproof."

OBSERVE POLARITY

When you replace the cells, be sure to observe the polarity of the battery circuit. The cells are held each in place with specially designed spring clips which also act as battery contacts. Battery polarity is shown on the panel.

RECTIFIER REPLACEMENT AND RECALIBRATION

There are two small rectifiers which are located at the top of the printed circuit, near the large 1.5 volt cell. These are used to rectify the A.C. voltages for measurement. They are shown as D-1 and D-2 in the overall schematic diagram, Fig. 2.

Both rectifiers act in the meter circuit to effectively create a full wave rectifying action. If either or both should fail, the meter will show incorrect indications.

In case of rectifier failure, replace the defective rectifier with another 1N87G, and be sure to observe polarity when you connect it into the circuit. If a type 1N87G is not available, use any good quality small crystal rectifier as a replacement.

After you replace either or both rectifiers, test the accuracy of A.C. voltage indications. If necessary, recalibrate the circuit by adjusting rheostats R-28 and R-31 as follows:

Maintenance

1. Set the function switch at A.C. and the range switch at 250 V.
2. Connect the red test lead in the + jack and the black test lead in the COMMON – jack.
3. From a standard voltage source, apply 250 volts A.C. to the red and black test leads. Adjust rheostat R-31, located in the upper right hand corner of the printed circuit board, so the meter reads full scale. Turn power off.
4. Set the range switch to 2.5 V. Apply 2.5 volts A.C. to the red and black test leads. Adjust rheostat R-28, located just to the right of the transistor, so the meter reads full scale. Turn power off.

If no standard voltage supply is available for the above procedure, use this alternate method:

1. Set the function switch at A.C., and the range switch at 2.5 V.
2. Connect the red test lead in the + jack and the black test lead in the COMMON – jack.
3. Connect the test leads to a fresh 1.5 volt flashlight cell. Connect the red test lead to the positive post of the battery and the black test lead to the negative post.
4. Adjust rheostat R-28 fully clockwise.
5. Adjust R-31 so that the meter reads 1.8 volts on the 2.5 V.A.C. ONLY arc.
6. Adjust R-28 so the meter pointer moves back to 1.71 volts on the same arc (the pointer will indicate 6 on the OHMS scale when it is in this position).

Maintenance

RESISTOR REPLACEMENT

Almost all of the resistors for the Simpson 260, Series 5P are mounted on the rear of the printed circuit. This makes them easily accessible for trouble-shooting and repair.

When it is necessary to replace any of the resistors in the circuit, first obtain an exact equivalent resistor. Order it from your nearest Simpson Parts Depot (see page 38) and specify the Simpson part number as it is shown in the parts list. Then clip the defective resistor off the printed circuit board, leaving the leads in the board to use as connections for the replacement.

Carefully twist the leads for the new resistor around the leads left from the defective resistor, and solder each connection. Trim away all excess and see that you have not caused any short circuit to any other part nearby.

REMOVING THE PRINTED CIRCUIT BOARD

When you require access to the under-side of the printed circuit board, or to the parts which are located between it and the front panel, remove the printed circuit board in the following manner.

1. Set the function switch at +D.C. and the range switch at 2.5 V.
2. Remove the knob for the ZERO OHMS control.
3. Remove the two screws through the lower part of the printed circuit board.
4. Remove the two hex nuts from the meter studs on the top of the printed circuit board.

5. Lift the printed circuit board away from the front panel. The entire board, with the switch wafers in place, will come up in one piece.
6. After removal, do not turn knobs on front panel or move any rotors on switches until reassembled.

FUSE REPLACEMENT

Remove the front panel from the case, and remove the burned-out fuse from its holder. Replace with a 10 amp, 250 volt fuse, Buss type ABC or equivalent only.

Courtesy of Simpson260.com
 With Thanks To: Fred Scoles

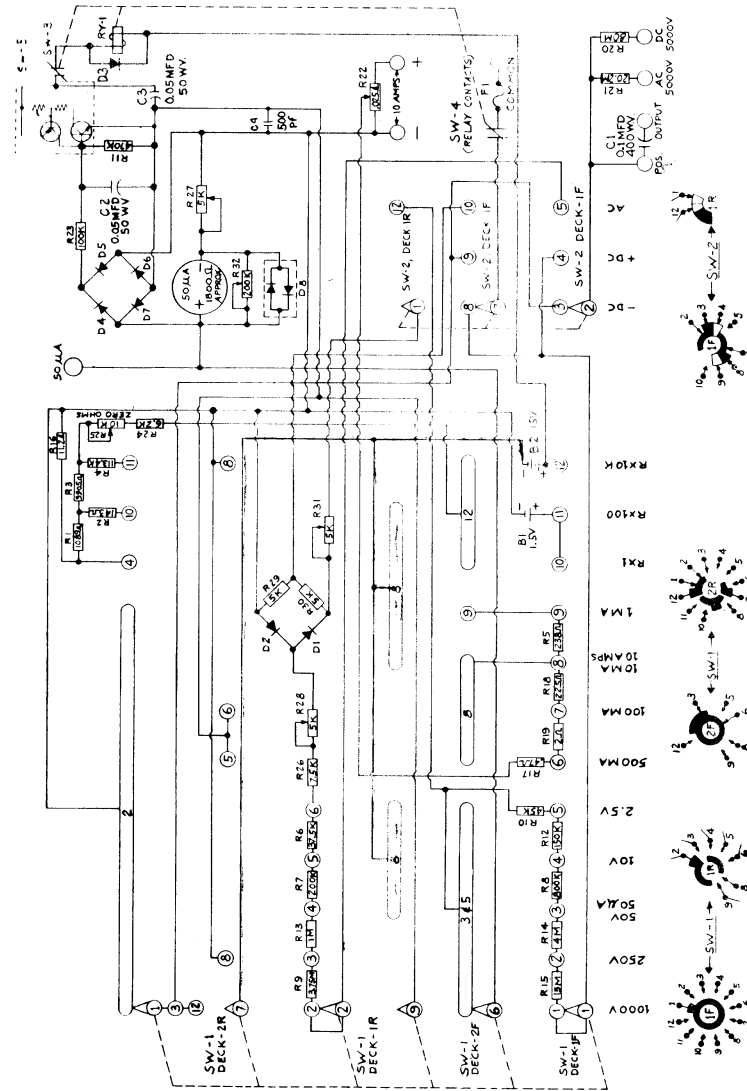

FIG. 2 OVERALL SCHEMATIC, SIMPSON VOLT-OHM-MILLIAMMETERS 260-5P

Maintenance

PARTS LIST

Reference Symbol	Description	Simpson Part No.
R1	Resistor, 1089 ohms	5-110153
R2	Resistor, 143 ohms	5-110154
R3	Resistor, 9905 ohms	5-110155
R4	Resistor, 113,405 ohms	5-110156
R5	Resistor, 238 ohms	5-110157
R6	Resistor, 37,500 ohms	5-110158
R7	Resistor, 200,000 ohms	5-110159
R8	Resistor, 800,000 ohms	5-110160
R9	Resistor, 3.75 megohms	1-115765
R10	Resistor, 45,000 ohms	5-110161
R11	Resistor, 470,000 ohms	1-114227
R12	Resistor, 150,000 ohms	5-110162
R13	Resistor, 1 megohm	5-110163
R14	Resistor, 113,400 ohms	1-113362
R15	Resistor, 15 megohms	1-115763
R16	Resistor, 11.2 ohms (wire-round)	5-110192
R17	Resistor, 0.47 ohm (wire-round)	5-110193
R18	Resistor, 22.5 ohms (wire-round)	5-110194
R19	Resistor, 2 ohms (wire-round)	5-110195
R20	Resistor, 80 megohms	1-113353
R21	Resistor, 20.2 megohms	1-116491
R22	Resistor, 0.025 ohm Shunt Ass'y. 10 Amp.	10-650058
R23	Resistor, 100,000 ohms	1-113949
R24	Resistor, 8200	1-111030
R25	Potentiometer, 10,000 ohms $\pm 30\%$	5-110164
R26	Resistor, 7500 ohms	5-110165
R27	Rheostat, 5000 ohms $\pm 10\%$	1-116254
R28	Rheostat, 5000 ohms $\pm 10\%$	1-116254

Maintenance

PARTS LIST

Reference Symbol	Description	Simpson Part No.
R29	Resistor, 5000 ohms	5-110166
R30	Resistor, 5000 ohms	5-110166
R31	Rheostat, 5000 ohms $\pm 10\%$	1-116254
R32	Potentiometer, 200,000 ohms $\pm 20\%$	1-110193
C1	Capacitor, 0.1 uf, 400 v.	1-113733
C2	Capacitor, 0.05 uf, 50V.	5-110191
C3	Capacitor, 0.05 uf, 50V	5-110191
C4	Capacitor, 500PF, 500V.	1-117046
D1-D2	Diode, Germanium '1N87G or equiv.	1-115970
D3-D7	Diode, Silicon	5-110185
D8	Diode, Protection	1-110670
F1	Fuse, 10 amp, 250 volt, Buss type ABC or equivalent	5-110187
RY-1	Relay	5-110181
SW-3	Switch	5-110179
SW-5	Electronic overload	10-861636
	Test lead set (one red and one black)	7500
	Case, Phenolic	3-320141
	Carrying Handle	10-860158
	Knobs	
	For Function Switch	1-115789
	For Zero Ohms Adjust	1-115790
	For Range Switch (less set screw)	3-260180
	Set Screw (for knob 3-260180)	1-114178
	Meter Assembly	13801
B1	Battery 1.5V Type 950 size "D"	1-111798
B2	Battery 15V No. 417	5-110176

SECTION IV
APPLICATIONS

GENERAL

The Simpson Volt-Ohm-Milliammeter 260, Series 5P is designed to measure almost all characteristics of elec-

Applications

trical and electronic circuits. It is the most versatile piece of test equipment which you can own.

In D.C. circuits, it will measure the voltage, the current, and the resistance. The measurements are made, through a very wide and common range, in terms of ordinary units for all values. Although the upper limit for D.C. voltage with the 260, Series 5P is 5000 volts, Simpson makes accessory multiplier probes to extend the range to 25,000 and 50,000 volts. By way of contrast, direct currents as small as 1 microampere can be read on the 50 microampere D.C. range.

For A.C. voltage measurements, the values are shown in terms of either R.M.S. volts on the basis of full wave rectification, or of decibels. The decibel ranges are based on the common arbitrary zero level of 1 milliwatt in 600 ohms.

Both portions of mixed A.C. and D.C. voltages can be read. The output circuit measures the A.C. portion, and the D.C. portion is indicated directly with the D.C. voltage circuit.

FORWARD AND REVERSE RECTIFIER RESISTANCES

The resistance of copper oxide, selenium, and crystal rectifiers can normally be measured in both directions. However, the resistance should be quite small in one direction (for forward polarity) and very large in the opposite direction. Use the ohmmeter circuit to determine that there is a large difference between the resistances in the two directions.

Applications

SIMPLE CAPACITOR CHECKS

The ohmmeter circuit can be used to identify good, open, and short conditions for many capacitors. Use the R x 10,000 range for best results.

A good capacitor will allow current to flow, deflecting the meter pointer, while it is charging up to the applied voltage. This produces a swing on the meter, with a gradual return of the pointer to infinity at the left hand side of the scale. The greater the capacity, the more the pointer will swing and the longer it will take for it to return to infinity.

If the capacitor is open, there will be no pointer deflection at the beginning of this test. Note that very small capacitors will have only a very slight deflection and a rapid return to infinity. Watch the meter closely when you test small capacitors.

If the capacitor is shorted, the pointer will not return to infinity. So when the pointer remains deflected on the ohms scale, and does not return, even slowly, this probably indicates a short in the capacitor.

Always reconfirm the results of these simple tests with more conclusive test equipment, or by replacement checks.

CAUTION: DISCHARGE CAPACITOR completely before connecting ohmmeter.

**ACCESSORY DC HIGH VOLTAGE PROBES
DC HIGH VOLTAGE TEST PROBES
(20,000 OHMS PER VOLT)**

PART NO. 0507	10,000 Volts DC
PART NO. 0508	25,000 Volts DC
PART NO. 0509	50,000 Volts DC

GENERAL DESCRIPTION

The DC high voltage probes extend the range of a 20,000 ohms per volt multimeter in a safe, convenient manner at nominal cost. Their primary purpose is the measurement of terminal potentials of very high voltage, very low power capacity direct current sources, examples of which are anode supplies used in television receivers and other cathode ray tube type circuitry.

The probe body is made of high temperature polystyrene in order to provide high dielectric strength and low leakage. It contains a high megohm precision resistor.

A shielded cable and internal probe shield are used to protect the operator from any possible flash-over and to ground any electrostatic charges that might accumulate on the probe body.

The internal shield and cable shield are connected to the ground return lead by a flexible copper braid between the two elbow connectors. A 48 inch ground return lead with an insulated clip completes the test lead set. No additional wires are needed.

ELECTRICAL SPECIFICATIONS

These D.C. high voltage probes are designed for use with the Simpson 260 (R); Series 5P or any 20,000 ohms per volt

Applications

tester having a 2.5 volt D.C. range and scale graduations from 0-10 or multiple thereof for the 10 KV probe, 0-25 or multiple thereof for the 25 KV probe, and 0-50 or multiple thereof for the 50 KV probe.

The DC high voltage test probes are available at your local electronics parts distributors.

The Volt-Ohm-Milliammeter, commonly called the Multimeter, has developed into one of the most valuable instruments in all electrical and electronic fields. The applications of the Multimeter are so numerous and varied that, without exception, they can be said to cover the entire field of electrical measurements.

Your 260-5P Multimeter has been carefully engineered to produce the most accurate, dependable and rugged instrument consistent with modern design techniques for the many applications in which it will be used. In view of the practically unlimited number of applications, it is suggested that text books be referred to regarding this subject in order to fully utilize the versatility of this instrument.

a handful is all
it takes...
for many tests

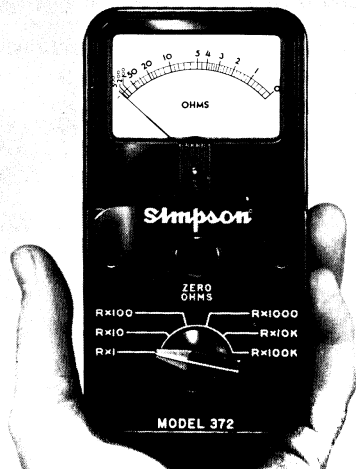

Simpson MICRO-TESTERS...18 Types...Get Several

If you run tests on communication systems, motors, wiring, appliances, tubes, components, batteries, or coolers, these nifty little testers are just what you're looking for. Micro-Testers measure only 3" x 5 7/8" x 2 1/2". They give you Simpson quality in a tester that is compact in both size and price. All 18 are in stock for immediate delivery. Call your Electronics Distributor or the factory for Bulletin 2066.

AC/DC VOLT-OHM-MILLIAMMETER: 12 ranges	Model 230
AC/DC VOLT-OHM-MILLIAMMETER: 14 ranges	Model 240
OHMMETER: 6 ranges, 0 ohms to 50 meg.	Model 372
LOW-OHMMETER: 0-5, 0-25 ohms	Model 362
AC AMMETER: 0-1, 2.5, 5, 10, 25 amp. ±5% FS.	Model 370
DC AMMETER: 0-1, 2.5, 5, 10, 25 amp. ±3% FS.	Model 375
AC MILLIAMMETER: 0-5, 25, 100, 250, 1000 ma. ±5% FS.	Model 378
DC MILLIAMMETER: 0-1, 5, 10, 25, 50, 100, 250, 1000 ma. ±3% FS.	Model 373
DC MICROAMMETER: 0-50, 100, 250, 500, 1000, 10000 ua ±3% FS.	Model 374
AC VOLTMETER: 0-5, 10, 25, 50, 100, 250, 500, 1000 v. ±5% FS.	Model 376
AC VOLTMETER: 0-150, 300, 600 v. ±3% FS.	Model 371
DC VOLTMETER: 10 ranges, 0 to 1000 v. ±3% FS.	Model 377
DC MILLIVOLTMETER: 0-10, 30, 100, 300, 1000 mv. ±3% FS.	Model 387
AC VOLT-AMP-WATTMETER: 8 ranges (300 v, 15 a, 3000 w, max) ±5% FS.	Model 390
AC/DC VOLT-WATTMETER: 4 ranges (250 v, 3000 w, max) ±5% FS.	Model 391
AC/DC VOLT-WATTMETER: 4 ranges (250 v, 5000 w, max) ±5% FS.	Model 392
BATTERY TESTER: for radios, flashlights, hearing aids	Model 379
TEMPERATURE METER: -50° to +70°F (up to 3 temp. one time)	Model 385-3L



SIMPSON ELECTRIC COMPANY
5206 W. Kinzie Street, Chicago, Ill. 60644
Phone: (312) ESTEbrook 9-1121
In Canada:
Bach-Simpson Ltd., London, Ontario

SIMPSON'S POPULAR EASY - TO - READ SEVEN INCH VOLT-OHM-MILLIAMMETER

Companions to the World Famous 260, Models 267 and 268 are ideal for TV and Radio service work, General Laboratory work, and Production Line testing where accurate repetitive readings are required. Simpson's 7" meter provides for expansion of all the meter scales making it easier to obtain closer repetitive readings.

One major switch in the tester selects range position and function at the same time which saves time in operation and also acts as a protection to the tester circuit.

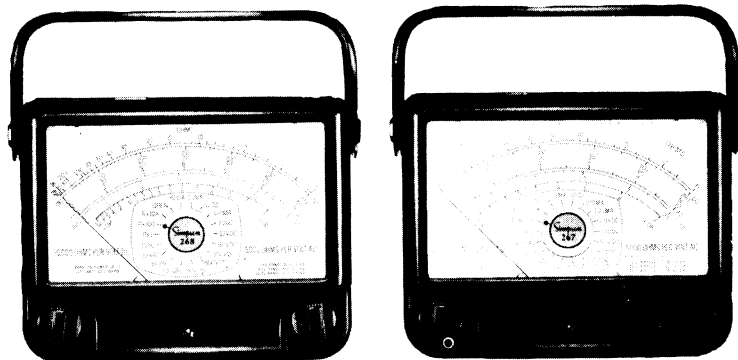

FEATURES

LOW MICROAMP RANGES: 0-50 (Model 267), 0-60 (Model 268)

EASIER TO READ SCALES: Black and Red scales have been spread out for faster reading, less chance for error.

LESS CIRCUIT LOADING: Sensitivity of AC Voltage ranges to 5000 ohms per volt.

POPULAR DBM RANGES: -20 DBM to +50 DBM one milliwatt in 600 ohms for "O" DB.

IMPROVED FREQUENCY RESPONSE IN AC MEASUREMENTS: 5 to 500,000 cycles per second ±2 DB.

FULL WAVE BRIDGE RECTIFIER SYSTEM: Provides more accurate AC voltage measurements.

ADJUST A VUE HANDLE; Allows convenient viewing angle.

RUGGED PRINTED CIRCUIT.

ALL COMPONENTS EASILY ACCESSIBLE.

Complete with operator's manual and test leads No. 7500

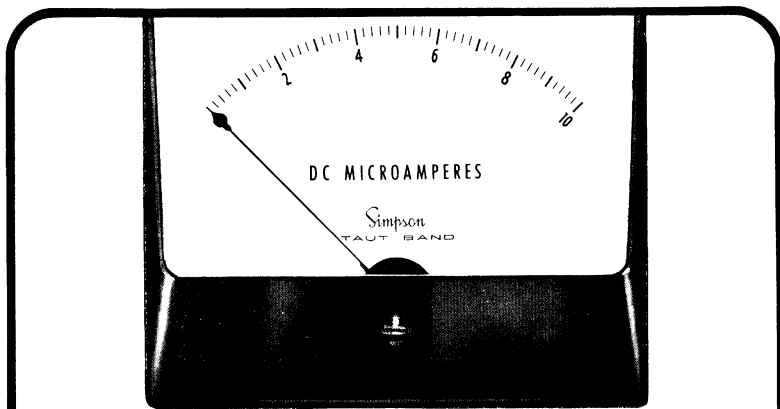

here's the taut band reliability you should demand

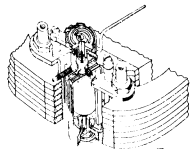

Simpson's search for reliability began at a major source of trouble—the overly complicated design of conventional Taut Band suspensions. The result was an improved suspension with 25% fewer parts.

Because of this, you would expect life expectancy to zoom, and trouble to nose dive. And that's just what happened.

The Ultimate in Test Programs—As just one step in a comprehensive test program to insure reliability measuring up to today's needs, Simpson engineers put 150 of the improved Taut Band meters on a continuing 24-hour test (cycled zero to full scale 2200 times per hour). As of August 30, 1964, the 150 meters have logged 25,243,000 cycles without failure. This is equivalent to over 70 years of normal operation. Weekly calibration checks show that the meters are holding $\pm 1/2\%$ accuracy. Simpson Taut Band meters also passed ASA tests for extreme temperature, humidity, shock, and vibration.

Stocked for Immediate Delivery—Present units stocked are microammeters in $2\frac{1}{2}''$, $3\frac{1}{2}''$, and $4\frac{1}{2}''$ sizes. Ranges are 10, 15, 25, 50, 100 μ a; accuracy, $\pm 2\%$ F.S. For fast service, call your distributor.

SIMPSON ELECTRIC COMPANY

5202 W. Kinzie Street, Chicago, Illinois 60644 • Phone: (312) EStebrook 9-1121

California: Simpson Instruments, Inc., P.O. Box 489, 1130 Simpson Way, Escondido, Calif. • Phone: (714) SH 5-8202

In Canada: Bach-Simpson Ltd., London, Ontario

In India: Huttonsha-Simpson Private Ltd., International House, Bombay-Agra Road, Vikrali, Bombay

INSTRUMENTS THAT STAY ACCURATE

Special Requirements—Contact your Simpson representative or the factory. Sensitivities as low as 2 microamperes at accuracies of 1% or better can be supplied.

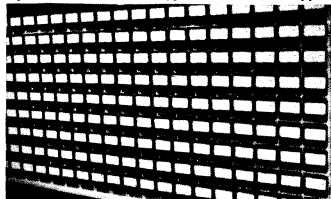

Continuing reliability tests being run on 150 improved Taut Band meters with 20 pivot-jewel meters used as control units.

WRITE FOR Bulletin PM-505.
Simpson
DIVISION

Representatives in Principal Cities

...See Telephone Yellow Pages

Warranty

SIMPSON ELECTRIC COMPANY warrants each instrument and other articles of equipment manufactured by it to be free from defects in material and workmanship under normal use and service, its obligation under this warranty being limited to making good at its factory any instrument or other article of equipment which shall within 90 days after delivery of such instrument or other article of equipment to the original purchaser be returned intact to it, or to one of its authorized service stations, with transportation charges prepaid, and which its examination shall disclose to its satisfaction to have been thus defective; this warranty being expressly in lieu of all other warranties expressed or implied and of all other obligations or liabilities on its part, and SIMPSON ELECTRIC COMPANY neither assumes nor authorizes any other persons to assume for it any other liability in connection with the sale of its products.

This warranty shall not apply to any instrument or other article of equipment which shall have been repaired or altered outside the SIMPSON ELECTRIC COMPANY factory or authorized service stations, nor which has been subject to misuse, negligence or accident, incorrect wiring by others, or installation or use not in accord with instructions furnished by the manufacturer.

Simpson

ELECTRIC COMPANY

5200 W. Kinzie Street, Chicago, Illinois 60644

Phone: (312) 379-1121

Export Dept: 400 W. Madison Street, Chicago, Illinois 60606, Cable, Simelco

IN CANADA: Bach-Simpson Ltd., London, Ontario

IN INDIA: Huttonsha-Simpson Private Ltd., International House, Bombay-Agra Road, Vikrali, Bombay



DIVISION