

# new VOMs

from

# Simpson

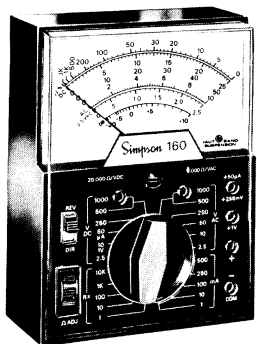

## 160 Handi-VOM

Just 3<sup>5</sup>/<sub>16</sub>" Wide . . .  
with Full-Size VOM Features

- 20,000  $\Omega$  VDC . . . 5,000  $\Omega$  VAC
- $\pm 2\%$  DC . . .  $\pm 3\%$  AC
- 5 Resistance Ranges . . . Plus a 0.1 to 100 DC Millivolt Range

## 313 Solid-State VOM

VTVM Features . . . VOM Conveniences

- Uses a single 9-volt battery
- 10 Meg  $\Omega$  DC . . . 11 Meg  $\Omega$  AC
- Large 7" scale

Write for bulletin 2080

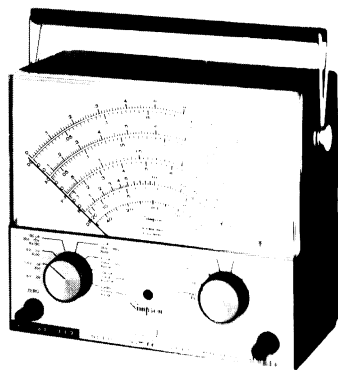

# OPERATOR'S MANUAL

Courtesy of Simpson260.com

With Thanks To: Jerry Brown

## VOLT-OHM-MILLIAMMETER 270 SERIES 4

SIMPSON ELECTRIC COMPANY

5200 West Kinzie Street - Chicago, Illinois 60644

Area Code 312, Telephone 379-1121

In Canada, Bach-Simpson, Ltd., London, Ontario

*Simpson* has over 1,400 stock  
sizes and types of panel instruments, too!

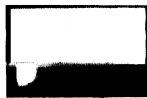

Write for bulletin 2011

Copyright, 1970, Simpson Electric Co.  
8-70 JMO HINZ

Printed in U.S.A.  
5-115103

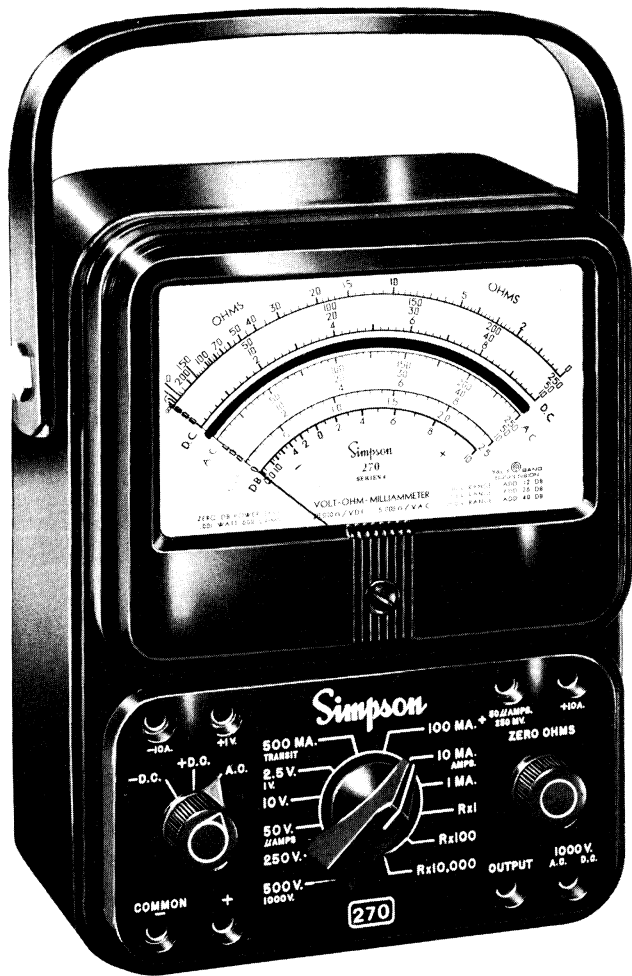

FIG. 1 270-4 VOLT OHM MILLIAMMETER

## TABLE OF CONTENTS

	Page
Specifications .....	4
Introduction .....	7
Section I General Description .....	9
Section II Operating Instructions .....	14
DC Voltage Measurements .....	16
AC Voltage Measurements .....	20
Output Voltage and Decibels Measurements .....	24
Direct Current Measurements .....	30
Resistance Measurements .....	34
Section III Maintenance .....	37
Parts List .....	41
Schematic Diagram .....	44
Section IV Accessories .....	45
Section V Applications .....	48

You have just purchased a Simpson 270. This instrument is a member of the world famous 260 family and is considered to be the standard VOM in many industries. In order to know the full capability of the instrument, read this manual carefully. See Page 37 for instructions on battery installation.

## SPECIFICATIONS

### RANGES

#### DC MILLIVOLTS

0-250 MV

Sensitivity: 20,000 ohms per volt

#### DC VOLTS

0-1-2.5-50-250-500-1000

Sensitivity: 20,000 ohms per volt

#### AC VOLTS

0-2.5-50-250-500-1000

Sensitivity: 5,000 ohms per volt

#### DC MICROAMPERES

0-50            250 MV Drop

#### DC MILLIAMPERES

0-1-10            250 MV Drop Approx.

0-100            280 MV Drop Approx.

0-500            400 MV Drop Approx.

#### DC AMPERES

0-10            250 MV Drop Approx.

#### OHMS

RX1            0-2,000            12 ohms center

RX100            0-200,000            1,200 ohms center

RX10,000            0-20 megohms            120,000 ohms center

## Specifications

Range	Nominal Open Circuit Voltage	Nominal Short Circuit Current
RX1	1.5	125 MA
RX100	1.5	1.25 MA
RX10,000	9.0	75 $\mu$ AMPS

#### OUTPUT VOLTS (AC)

0-2.5-10-50-250

#### DECIBELS

With zero DB power level equal to 1 milliwatt across a  
600 ohm line -20 to +10 DB

- 8 to +22 DB

+ 6 to +36 DB

+ 20 to +50 DB

#### BATTERIES

One 1.5 volt, NEDA 13F battery and one 9 volt, NEDA  
1604 battery.

#### FUSE

1 ampere, 250 volts. Type 3AG. Quick Acting.

#### TEST LEADS

One red and one black test lead, each approximately  
48 inches long. Two screw-on type alligator clips supplied.

#### SIZE

5-1/4" x 7" x 3-1/8"

#### WEIGHT

3 pounds

## Specifications

	ACCURACY	
<b>DC VOLTAGE</b>	77°F	67°–87°F
All ranges	1.25% F.S.*	1.75% F.S.
<b>AC VOLTAGE (See Note)</b>		
All ranges	2.0% F.S.	3.0% F.S.
<b>DC CURRENT</b>		
0–50 microamperes	.75% F.S.	1.25% F.S.
Other ranges	1.25% F.S.	1.75% F.S.
<b>RESISTANCE RANGES</b>		
R x 1      0–2000 Ω	1.5° of arc	1.75° of arc
R x 100    0–200,000 Ω	1° of arc	1.25° of arc
R x 10,000 0–20 megohms	1° of arc	1.25° of arc

### FREQUENCY RESPONSE

Referenced to response at 100 Hz when making level measurements. See curves on pages 22 and 27.

#### \*NOTE

Responds to the average value of an A.C. current and is calibrated to indicate the R.M.S. value of a pure sine wave.

\*F.S. = Full Scale

Accuracies specified are for the 270 in a horizontal position.

## INTRODUCTION

The Simpson Volt–Ohm–Milliammeter 270 Series 4 is a rugged, accurate, compact, easy-to-use instrument. The instrument can be used to make accurate measurements of D.C. and A.C. voltage, direct current, resistance, decibels and “Output Voltage”. It has a mirrored dial to eliminate parallax. The Output Voltage function is used for measuring the A.C. component of a mixture of A.C. and D.C. voltages. This occurs primarily in amplifier circuits.

The 270 Series 4 has the following new features: a 0-1 volt D.C. range, 0-500 volt and A.C. ranges, a TRANSIT position on the range switch, rubber plug bumpers on the bottom of the case to reduce sliding, improved test leads and an externally accessible battery and fuse compartment. Batteries and fuse can be changed quickly by loosening the single screw of the compartment cover on the bottom of the case.

Higher accuracy is achieved by the use of .5% resistors. To complement the circuit accuracy, the 270 features the new Simpson taut-band, annular movement. The annular movement provides self-shielding. The taut-band suspension provides a high degree of repeatability and is highly resistant to damage by shock or vibration.

Several internally located calibration circuits are provided to increase the initial accuracy of the 270 and to facilitate recalibration should it become necessary.

## Introduction

The 270 uses the most modern components and circuit techniques. It is assembled by well-trained personnel using quality materials and modern equipment. This combination of design, materials and skillful assembly results in a unit that will take considerable abuse and still provide accurate indication. If it is kept clean and is not unduly abused or misused, or subjected to extreme shock or vibration, the 270 will give many years of trouble-free service.

Courtesy of [Simpson260.com](http://Simpson260.com)

**With Thanks To: Jerry Brown**

## SECTION I

### GENERAL DESCRIPTION

#### ACCURACY

The 270-4 has the same physical configuration and ranges as the 260-6 but has higher accuracy. The higher accuracy is achieved by the use of .5% resistors combined with an instrument movement in which maximum precautions have been taken to minimize error.

The change in accuracy with a 10°F temperature change is  $\pm 1/2\%$  of full scale on D.C. ranges and  $\pm 1\%$  of full scale on A.C. ranges. These accuracy changes are linear over the temperature range of 67° to 87°F, being  $\pm .05\%$  per °F on D.C. and  $\pm .1\%$  per °F on A.C.

#### FRONT PANEL

The instrument has a large easy-to-read 4-1/2" indicating instrument at the top of the front panel. Below the indicating instrument are three operating controls and eight circuit jacks. All switch positions and circuit jacks are marked with white characters on black background to insure long-lasting, easy readability.

#### RANGE SWITCH

The range switch is located in the center of the lower part of the front panel and has 12 positions. It may be turned in either direction. There are five voltage positions, four direct current positions and three resistance positions.

## General Description

### FUNCTION SWITCH

The function switch is on the lower left of the front panel. It has three positions: -D.C., +D.C. and A.C. To measure current D.C. voltage or resistance, set the function switch at -D.C. or +D.C. according to the polarity of applied current or voltage. The function switch permits reversal of the test lead connections without removing the leads from the circuit under test.

### ZERO OHMS

The control at the lower right on the panel is marked ZERO OHMS. It is a variable resistor in the ohmmeter circuit that compensates for variations in the voltage of the internal batteries.

### CIRCUIT JACKS

There are eight jacks, two in each corner of the front panel. These are the connectors for the test leads. Plug the elbow prods of the test leads into the proper jacks to obtain the circuit and range desired for each application.

At the lower left are - COMMON and + jacks. Connect the black test to - COMMON for all circuits and ranges except 10 amperes D.C. Connect the red test lead to the + jack for all circuits and ranges except those designated by the other circuit jacks.

Across the top of the panel are jacks marked -10A., +1V., dual marking of +50  $\mu$ AMPS and +250 MV at a single jack and +10A. For the 50 microampere or 250 millivolt D.C. range, connect the red test lead to this dual marked jack. For the 10 ampere D.C. range, use the black test lead in the -10A. jack and the red test lead in the +10A. jack.

At the lower right are OUTPUT and 1000 V. jacks. For all audio frequency output ranges, connect the red test lead to the OUTPUT jack. For 1000 volts A.C. or D.C., connect the red test lead to the 1000 V. jack.

### PHENOLIC CASE

The phenolic case is designed with heavy reinforced walls for maximum durability and provides excellent protection for the circuit components.

The case has an externally accessible battery and fuse compartment. Access to the batteries and fuse is obtained by unscrewing a single captivated screw at the bottom of the case and sliding out the compartment cover. A spare fuse is also provided in the compartment.

Rubber plug bumpers on the bottom of the case reduce sliding should the 270 be accidentally pulled by the test leads when the instrument is on a workbench.

### PRINTED CIRCUIT

Most of the component parts are mounted on a printed circuit board which simplifies assembly and maintenance, thus extending the useful life of the instrument.

## General Description

### ADJUST-A-VUE HANDLE

A carrying handle is attached to the sides of the instrument case. The handle may be used to support the instrument in a convenient, sloping position for easy viewing. The VOM case can also be placed in either a vertical or horizontal position. The horizontal position is preferable for greater accuracy since the instrument is calibrated in this position.

### TEST LEADS

Each instrument is furnished with one pair of test leads 4 feet long. One lead is black and the other red for easy polarity identification. The test lead wire consists of a large number of fine strands and is very flexible.

The insulation of the wire is high-grade rubber and is more than adequate for the highest voltage that the instrument will measure. The red and black test leads have probe tips which are threaded near the base. The alligator clips may be screwed on or off either test lead to provide a probe or a clip for the operator's convenience.

### TEST LEAD INSPECTION

Periodic inspection of the test leads is recommended to detect cuts, burned areas or other damage that could reduce the insulation strength of the leads. When replacement is indicated, order catalog number 00115 from your local parts distributor.

### FUSE PROTECTION

A 1 ampere 250 V. fuse is provided to protect the 270 circuits from misuse on the ohmmeter ranges and from excessive overloads on the milliampere ranges. If the instrument fails to indicate, the fuse may be burned out. See Section III, MAINTENANCE, for fuse replacement. A spare fuse is furnished with the 270. Both fuses are located in the battery and fuse compartment.

### MOVEMENT OVERLOAD PROTECTION

In addition to the fuse, a varistor protects the indicating instrument circuit. The varistor limits the current through the moving coil in case of overload.

The fuse and varistor will prevent serious damage to the 270 in most cases of accidental overload. However, no overload protection system is completely foolproof and misapplication on high voltage circuits can damage the instrument. Care and caution should always be exercised to protect both you and your VOM.

### INTERNAL BATTERIES

There are two batteries in the ohmmeter circuits. One is a NEDA 13F D size cell that furnishes 1.5 volts for the R x 1 and R x 100 ranges. A NEDA 1604 battery furnishes 9 volts for the R x 10,000 range. The 1.5 volt D cell is held in place with two spring clips which also serve as battery contacts.

## Operating Instructions

The polarity symbols for the D cell are marked near the battery contacts. The 9 volt battery is held in place with a spring clip but contact is made with a separate connector that is polarized. Always observe correct polarity when replacing the 1.5 volt D cell.

### SECTION II

#### OPERATING INSTRUCTIONS

##### UNPACKING

After unpacking the 270 you will find the 1.5 volt and 9 volt batteries in a polyethylene bag inside the box with the instrument and test leads. Two alligator clips for the test leads are in another polyethylene bag. See Section III, MAINTENANCE, for instructions on how to open the battery compartment and install the batteries.

##### ADJUST POINTER FOR ZERO

With the volt-ohm-milliammeter in operating position, check that the pointer indicates zero at the left side of the scale when there is no input to the 270. If pointer is off zero, adjust the screw located in the case below center of the dial. Use a small screwdriver to turn the screw slowly clockwise or counterclockwise until the pointer is exactly over the zero mark at the left side of the scale. With the indicating pointer set on the zero mark, reverse the direction of rotation of the zero adjuster. Rotate the zero adjuster a sufficient amount to introduce mechanical freedom or "play" but insufficient to

## Operating Instructions

disturb the position of the indicating pointer. This procedure will eliminate disturbances to the zero setting from subsequent changes in temperature, humidity, vibration and other environmental conditions.

##### POLARITY CORRECTION

When making D.C. measurements with the test leads connected to the + and - COMMON jacks, polarity can be reversed with the function switch without reversing the test leads. When making measurements on the 50 uAMPS/250 MV range, 1 volt D.C. range or 10 A range, polarity can be corrected only by reversing the test leads.

##### CAUTION

Before making measurements, turn off the power to the circuit being measured. Discharge any capacitors in the circuit undergoing measurement. Connect test leads to circuit being measured and turn on power. When measuring high voltage, never touch the 270, the test leads or test probes with the power supply turned on. After making the measurement, turn off power to the circuit being measured before disconnecting the test leads.

The alligator clips provided with the test leads screw onto the probe tips. Each alligator clip is covered with a rubber insulator to provide additional protection against electrical shock. When measuring high voltages, the use of the clips will permit measurement without handling the test probes.



**Operating Instructions**

Be sure power to circuit being measured is shut off before connecting or disconnecting the slips even though they are covered with insulators.

The range switch or function switch positions should be changed only when the power to the circuit being measured is turned off or when the test leads are disconnected. This will eliminate arcing at the switch contacts and prolong the life of the 270..

**D.C. VOLTAGE MEASUREMENTS**

**MEASURING D.C. VOLTAGE**

**0--250 MILLIVOLTS**

**CAUTION**

When using the 270 as a millivoltmeter, care must be taken to prevent damage to the indicating instrument from excessive voltage. Before using the 250 millivolt range, first use the 1.0 volt D.C. range to determine that the voltage measured is no greater than 250 millivolts (or .25 volt D.C.).

1. Set the function switch at +D.C.
2. Plug the black test lead in the -COMMON jack and the red test lead in the +50 uAMPS/250 MV jack.
3. Set the range switch at 50 uAMPS (dual position with 50 V.).
4. Connect the black test lead to the negative side of the circuit being measured and the red test lead to the positive side of the circuit.

5. Read the voltage on the black scale marked D.C. and use the figures marked 0-250. Read directly in millivolts.

**MEASURING D.C. VOLTAGE**

**0-1 VOLT**

1. Set the function switch at +D.C.
2. Plug the black test lead in the -COMMON jack and the red test lead in the +1 V. jack.
3. Set the range switch at 1 V. (dual position with 2.5 V.).
4. Connect the black test lead to the negative side of the circuit being measured and the red test lead to the positive side of the circuit.
5. Read the voltage on the black scale marked D.C. Use the figures marked 0-10 and divide the reading by 10.

**MEASURING D.C. VOLTAGE**

**0-2.5 THROUGH 0-500 VOLTS**

1. Set the function switch on the left side of the front panel at +D.C.
2. Plug the black test lead in the -COMMON jack and the red test lead in the + jack.

## Operating Instructions

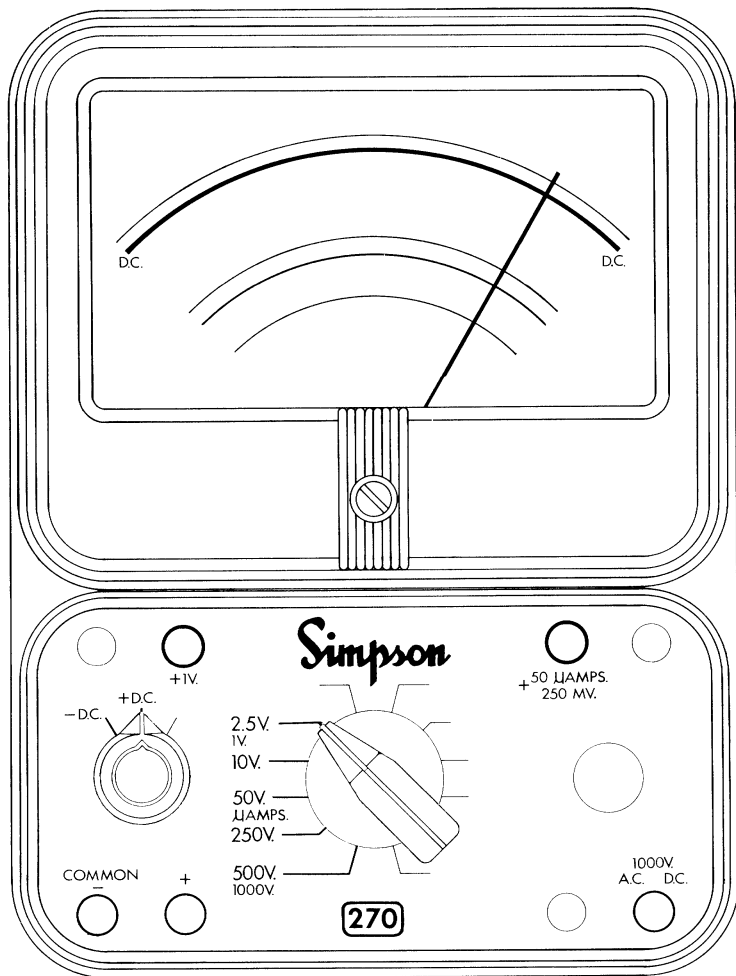

FIG. 2 JACKS AND SWITCH POSITIONS FOR MEASURING D.C. VOLTAGE

## Operating Instructions

3. Set the range switch at one of the five voltage range positions marked 2.5 V., 10 V., 50 V., 250 V. or 500 V. When in doubt as to the voltage present, always use the highest voltage range as a protection to the instrument. If the voltage is within a lower range, the switch may be set for the lower range to obtain a more accurate reading.
4. Connect the black test lead to the negative side of the circuit being measured and the red test lead to the positive side of the circuit.
5. Read the voltage on the black scale marked D.C. For the 2.5 V. range, use the 0-250 figures and divide by 100. For the 10 V., 50 V., and 250 V. ranges, read the figures directly. For the 500 V. range, use the 0-50 figures and multiply by 10.

### MEASURING D.C. VOLTAGE 0--1000 VOLTS

#### WARNING

Be extremely careful when working with high voltage circuits. Do not touch the instrument or test leads while power is on in the circuit being measured.

1. Set the function switch at +D.C.
2. Set the range switch at 1000 V. (dual position with 500 V.).

## Operating Instructions

3. Plug the black test lead in the -COMMON jack and the red test lead in the 1000 V. jack.
4. Be sure power is off in the circuit being measured and all capacitors have been discharged. Connect the black test lead to the negative side of the circuit being measured and the red test lead to the positive side of the circuit.
5. Turn on the power in the circuit being measured.
6. Read the voltage using the 0-10 figures on the black scale marked D.C. Multiply the reading by 100.

NOTE: To measure higher D.C. voltage, see Section IV, ACCESSORIES, for higher voltage accessory probes.

## A.C. VOLTAGE MEASUREMENTS

### MEASURING A.C. VOLTAGE

(See **CAUTION** note under **OPERATING INSTRUCTIONS**)

#### 0--2.5 THROUGH 0--500 VOLTS

#### CAUTION

When measuring line voltage such as from a 120 volt, 240 volt or 480 volt source, be sure that the range switch is set to the proper voltage position.

## Operating Instructions

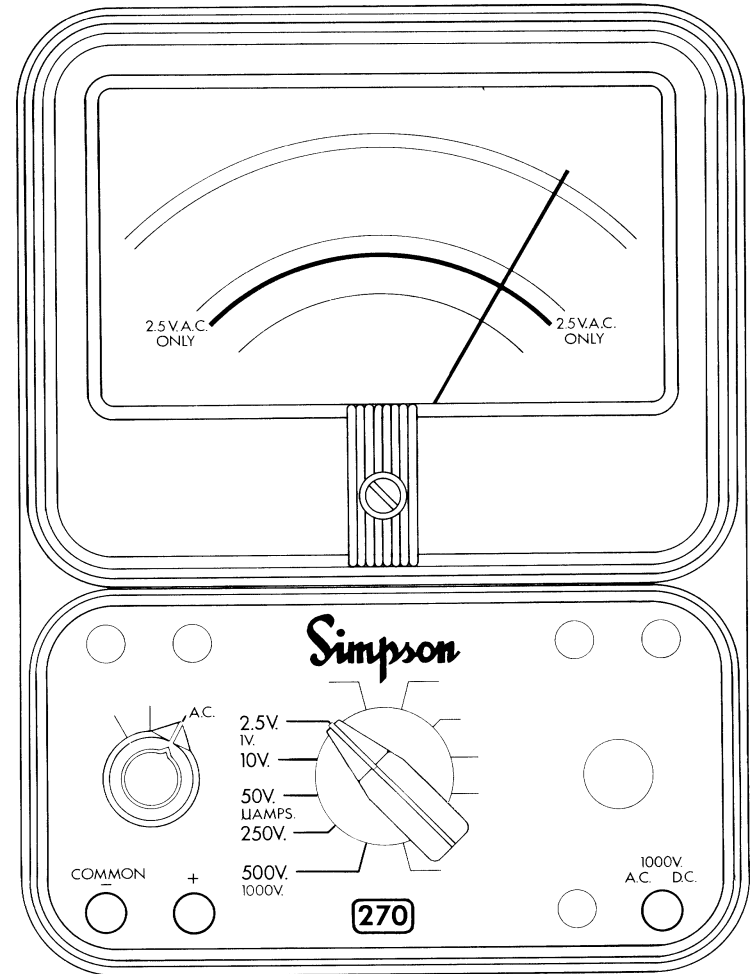

FIG. 3 JACKS AND SWITCH POSITIONS FOR MEASURING A.C. VOLTAGE

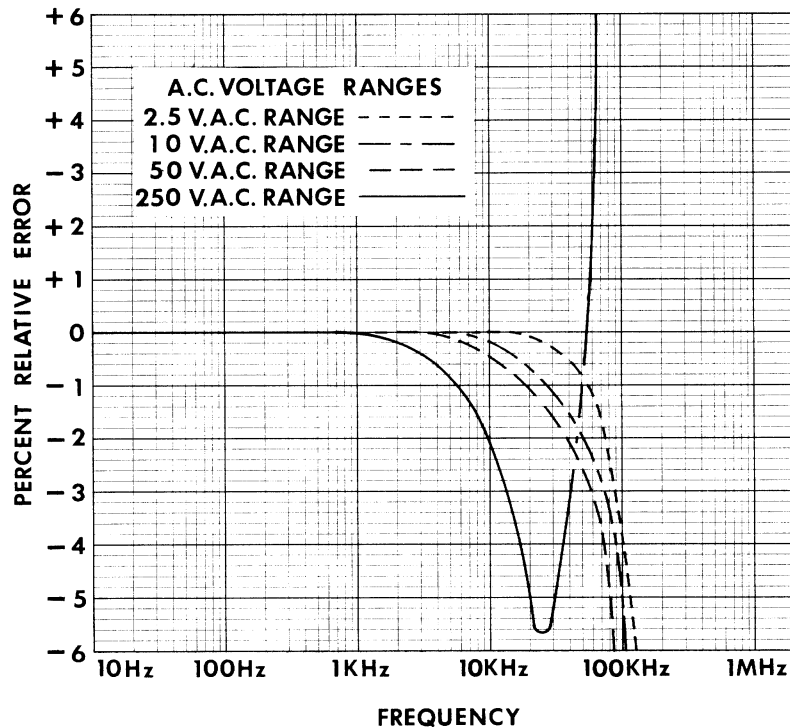

FIG. 4 FREQUENCY RESPONSE A.C. VOLTAGE RANGES

The Simpson 270 responds to the average value of an A.C. waveform. It is calibrated in terms of the R.M.S. value of a pure sine wave. If the waveform is nonsinusoidal, and depending upon its waveform, the reading may be either higher or lower than the true R.M.S. value of the measured voltage. Thus an error may be introduced if the 270 is used to measure a nonsinusoidal waveform.

1. Set the function switch at A.C.
2. Set the range switch at one of the five voltage range positions marked 2.5 V., 10 V., 50 V., 250 V. or 500 V. When in doubt as to the actual voltage present, always use the highest voltage range as a protection to the instrument. If the voltage is within a lower range, the switch may be set for the lower range to obtain a more accurate reading.
3. Plug the black test lead in the -COMMON jack and the red test lead in the + jack.
4. Connect the test leads across the voltage source.
5. Turn on power in the circuit being measured.
6. For the 0-2.5 V. range, read the value directly on the scale marked 2.5 V. A.C. ONLY. For the 10 V. 50 V. and 250 V. ranges, read the red scale marked A.C. and use the black figures immediately above the scale. For the 500 V. range, read the red scale marked A.C. and use the 0-50 figures. Multiply the reading by 10.

## Operating Instructions

### MEASURING THE A.C. VOLTAGE

#### 0--1000 VOLTS

#### CAUTION

Be extremely careful when working in high voltage circuits. Do not touch the instrument or test leads while power is on in the circuit being measured.

1. Set the function switch at A.C.
2. Set the range switch at 1000 V. (dual position with 500 V.).
3. Plug the black test lead in the -COMMON jack and the red test lead in the 1000 V. jack.
4. Be sure the power is off in the circuit being measured and that all its capacitors have been discharged. Connect the test leads to the circuit.
5. Turn on the power in the circuit being measured.
6. Read the voltage on the red scale marked A.C. Use the 0-10 figures and multiply by 100.

### OUTPUT VOLTAGE AND DECIBEL MEASUREMENTS

#### MEASURING OUTPUT VOLTAGE

It is often desired to measure the A.C. component of an Output Voltage where both A.C. and D.C. voltage levels exist. This occurs primarily in amplifier circuits.

## Operating Instructions

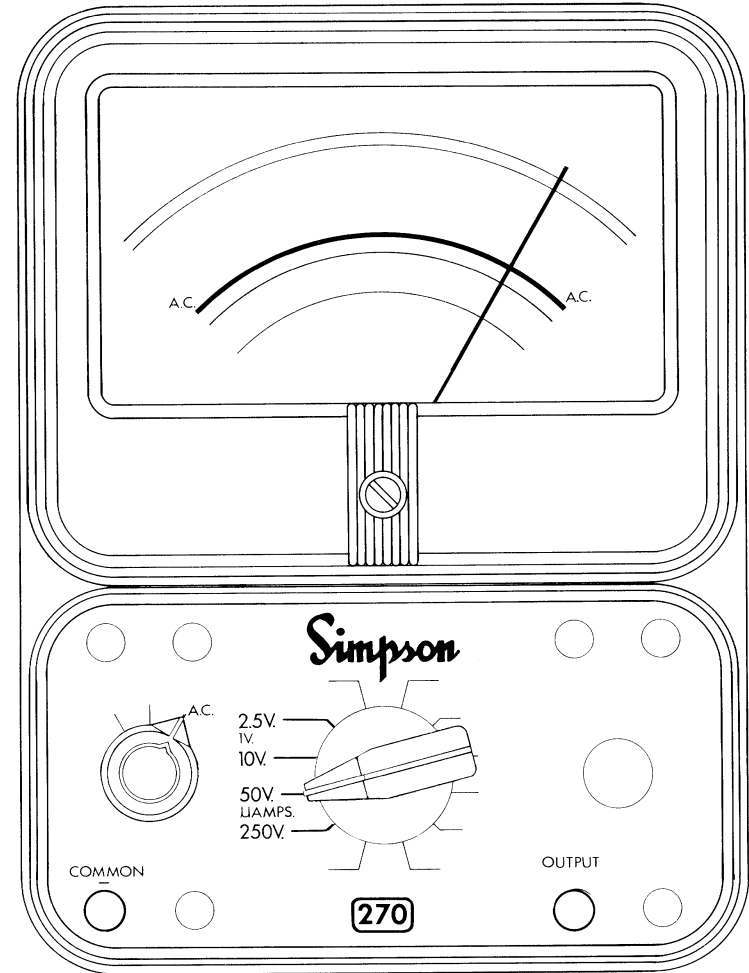

FIG. 5 JACKS AND SWITCH POSITIONS FOR MEASURING OUTPUT

## Operating Instructions

The 270 has a .1 mfd, 400 volt capacitor in series with the OUTPUT jack. The capacitor blocks the D.C. component of the current in the test circuit, but allows the A.C. or desired component to pass on to the indicating instrument circuit. The blocking capacitor may alter the A.C. response at low frequencies but is usually ignored at audio frequencies.

### CAUTION

When using OUTPUT, do not apply to a circuit whose D.C. voltage component exceeds the 400 volt rating of the blocking capacitor.

1. Set the function switch at A.C.
2. Plug the black test lead in the -COMMON jack and the red test lead in the OUTPUT jack.
3. Set the range switch at one of the range positions marked 2.5 V., 10 V., 50 V. or 250 V.
4. Connect the test leads across the circuit being measured with the black test lead to the ground side.
5. Turn on the power in the test circuit. Read the output voltage on the appropriate A.C. voltage scale. For the 0-2, 5 V. range, read the value directly on the scale marked 2.5 V. A.C. ONLY. For the 10 V., 50 V., or 250 V. ranges, use the red scale marked A.C. and read the black figures immediately above the scale.

## Operating Instructions

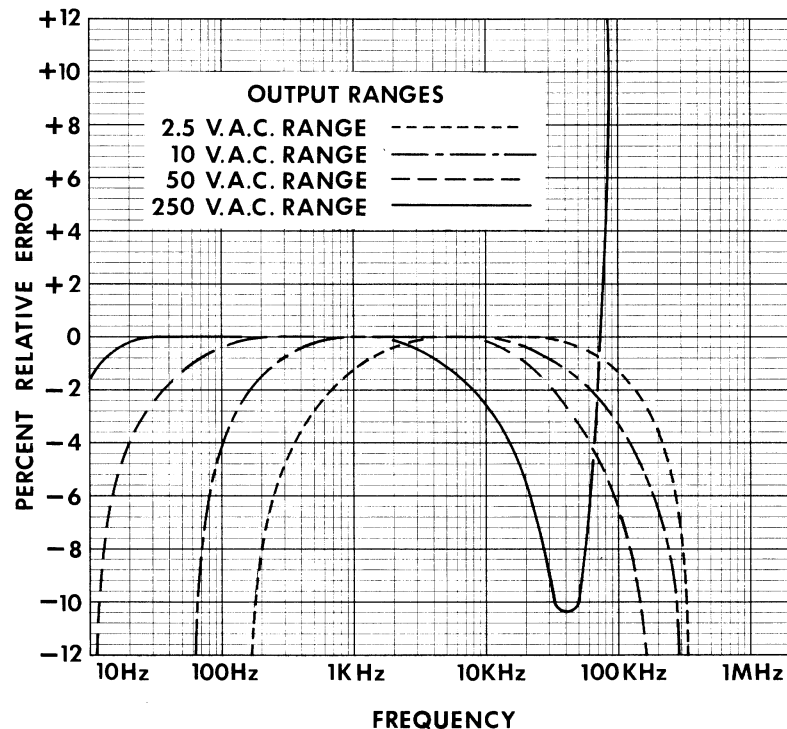

FIG. 6 FREQUENCY RESPONSE OUTPUT RANGES

## Operating Instructions

### MEASURING DECIBELS

For some applications, output voltage and audio frequency voltage are frequently measured in terms of decibels. The decibel scale (DB) at the bottom of the dial is marked from -20 to +10.

To measure decibels, read the DB scale in accordance with instructions for measuring A.C. For example, when the range switch is set on the 2.5 V. position, the DB scale is read directly.

The DB readings on the scale are referenced to zero DB power level of .001 watt in 600 ohms, or .775 V. A.C. across 600 ohms.

For the 10 V. range, read the DB scale and add +12 DB to the reading. For the 50 V. range, read the DB scale and add +26 DB to the reading. For the 250 V. range, read the DB scale and add +40 DB to the reading.

If the zero DB reference level is .006 watt in 500 ohms, subtract 7 DB from the reading.

## Operating Instructions

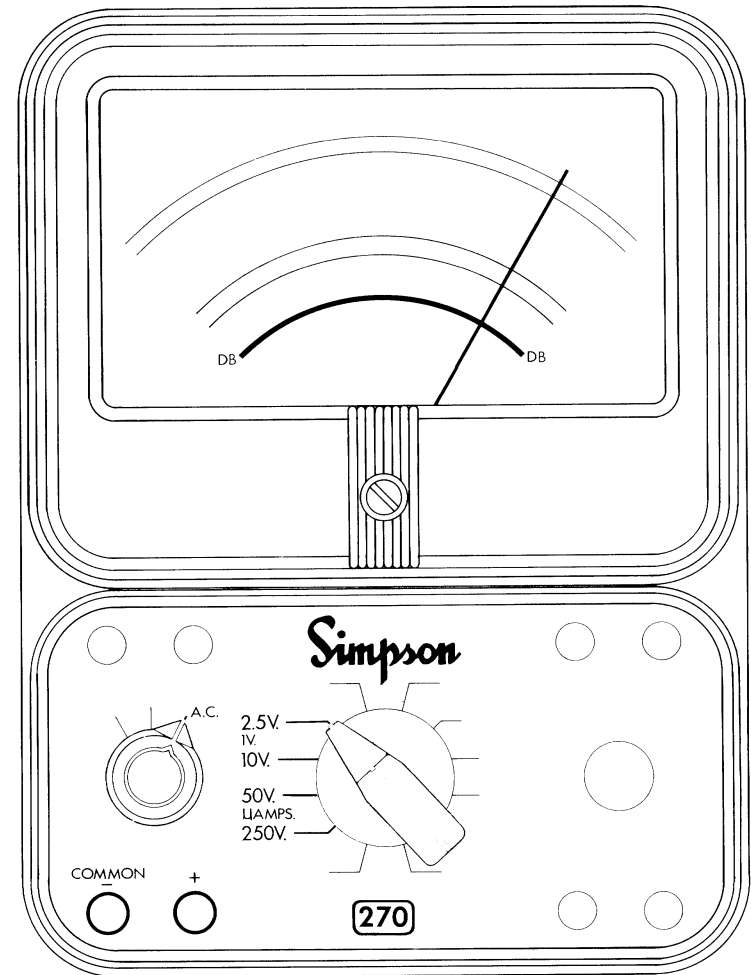

FIG. 7 JACKS AND SWITCH POSITIONS FOR MEASURING DECIBELS

## Operating Instructions

### DIRECT CURRENT MEASUREMENTS

(See **CAUTION** note under **OPERATING INSTRUCTIONS**)

#### VOLTAGE DROP

The voltage drop across the 270 on all milliampere current ranges is approximately 250 millivolts measured at the jacks. An exception is the 0-500 MA range with a drop of approximately 400 millivolts. The voltage drop will not affect most circuits whose current is being measured. In some transistor circuits, it may be necessary to compensate for the added voltage drop when making measurements.

#### MEASURING DIRECT CURRENT

##### 0-50 MICROAMPERES

#### CAUTION

Never connect the test leads directly across voltage when the 270 is used as a current indicating instrument. Always connect the instrument in series with the load across the voltage source.

1. Set the function switch at +D.C.
2. Plug the black test lead in the -COMMON jack and the red test lead in the +50 uAMPS/250 MV jack.
3. Set the range switch at 50 uAMPS (dual position with 50 V.).

## Operating Instructions

4. Open the circuit in which the current is being measured. Connect the instrument in series with the circuit. Connect the red test lead at the positive side and the black test lead at the negative side.
5. Read the current on the black D.C. scale. Use the 0-50 figures to read directly in microamperes.

NOTE: In all direct current measurements, be certain the power to the circuit being tested has been turned off before disconnecting test leads and restoring circuit continuity.

The internal voltage drop of the 270 on the 50 microampere range is 250 millivolts. The 50 microampere range serves as a dual function. Either 50 microamperes D.C. or 250 millivolts D.C. can be measured at this single jack position.

#### MEASURING DIRECT CURRENT

##### 0-1 THROUGH 0-500 MILLIAMPERES

1. Set the function switch at +D.C.
2. Plug the black test lead in the -COMMON jack and the red test lead in the + jack.
3. Set the range switch at one of the four range positions marked 1 MA., 10 MA., 100 MA., or 500 MA.
4. Open the circuit in which the current is being measured. Connect the VOM in series with the circuit. Connect the red test lead to the positive side and the black test lead to the negative side.



## Operating Instructions

5. Read the current in milliamperes on the black D.C. scale. For the 1 MA. range, use the 0–10 figures and divide by 10. For the 10 MA. range use the 0–10 figures and multiply by 10. For 500 MA. range, use the 0–50 figures and multiply by 10.

### MEASURING DIRECT CURRENT

#### 0–10 AMPERES

1. Plug the black test lead in the –10 A. jack and the red test lead in the +10 A. jack.
2. Set the range switch at 10 AMPS (dual position with 10 MA.).
3. Open the circuit in which the current is being measured. Connect the instrument in series with the circuit. Connect the red test lead at the positive side and the black test lead at the negative side.

NOTE: The function switch has no effect on polarity for the 10 AMPS range.

4. Read the current on the black D.C. scale. Use the 0–10 figures to read directly in amperes.

#### CAUTION

When using the 10 ampere range, never remove a test lead from its panel jack while current is flowing through the circuit. Otherwise damage may occur to the banana plug and jack.

## Operating Instructions

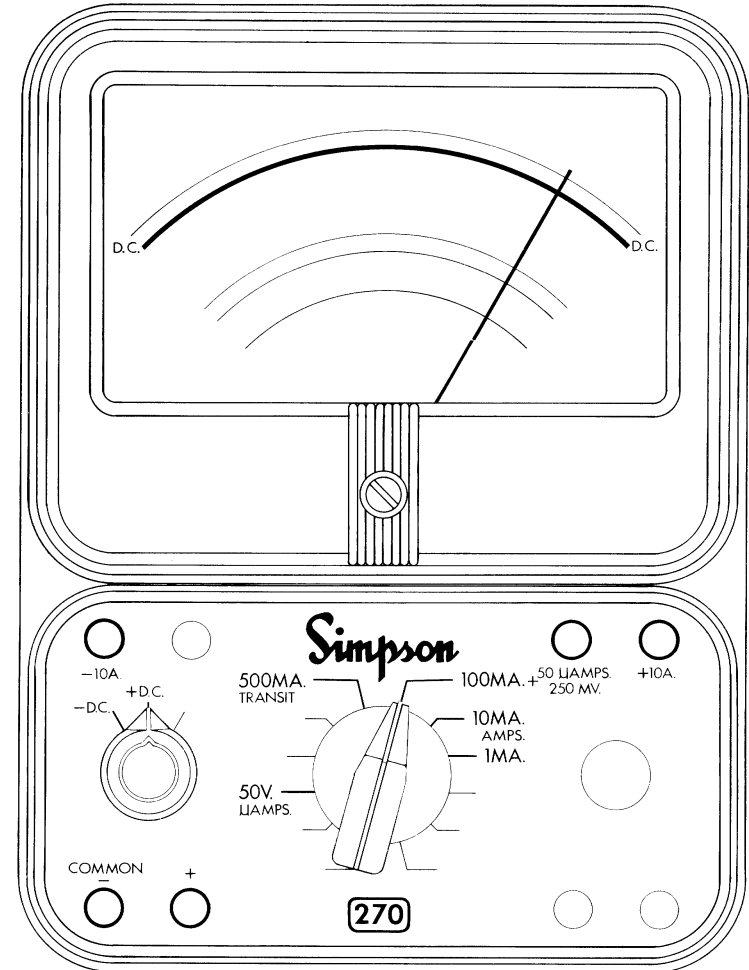

FIG. 8 JACKS AND SWITCH POSITIONS FOR MEASURING DIRECT CURRENT

## Operating Instructions

### TRANSIT

The 500 MA. range switch position is also the TRANSIT position. The additional damping of the movement in the TRANSIT position will reduce pointer swing when the 270 is carried.

### RESISTANCE MEASUREMENTS

#### ZERO OHMS ADJUSTMENT

When resistance is measured, VOM batteries B1 and B2 furnish power for the circuit. Since batteries are subject to variation in voltage and internal resistance, the instrument must be adjusted to zero prior to measuring a resistance, as follows:

1. Turn range switch to desired ohms range.
2. Plug the black test lead in the -COMMON jack and the red test lead in the + jack.
3. Connect ends of test leads to short the VOM resistance circuit.
4. Rotate the ZERO OHMS control until pointer indicates zero ohms. If pointer cannot be adjusted to zero, one or both of the batteries must be replaced. For battery replacement, see Section III, MAINTENANCE.
5. Disconnect ends of test leads and connect to component being measured.

## Operating Instructions

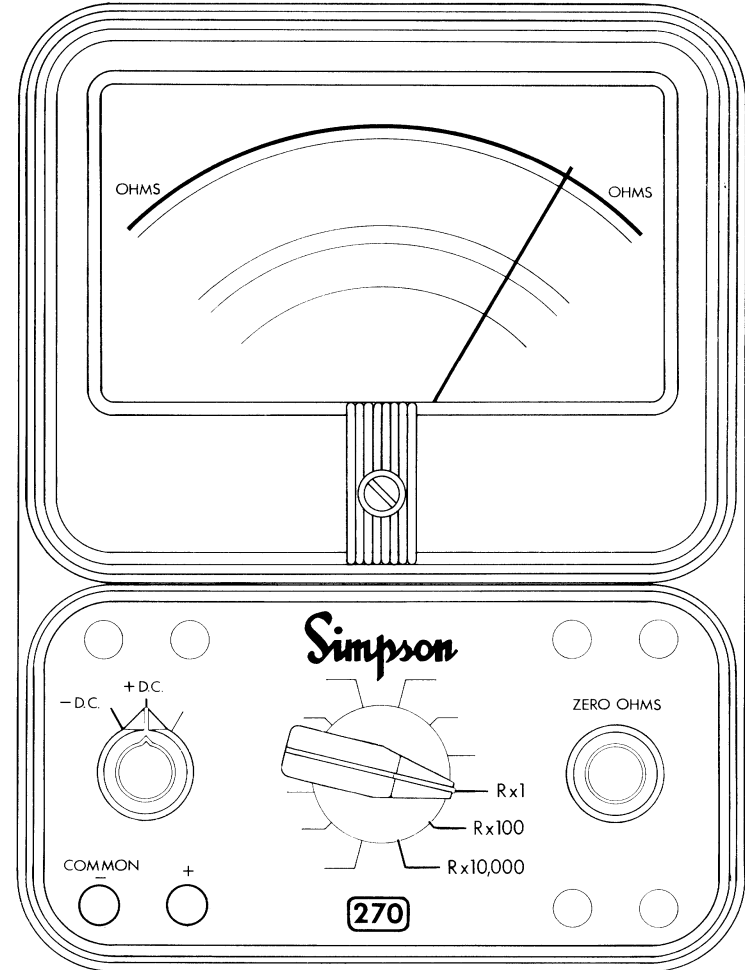

FIG. 9 JACKS AND SWITCH POSITIONS FOR MEASURING RESISTANCE

## Operating Instructions

### MEASURING RESISTANCE

#### CAUTION

Before measuring resistance, be sure power is off to the circuit being tested. Disconnect the component from the circuit before measuring its resistance.

Set the range switch to one of the resistance range positions as follows:

1. Use R x 1 for resistance readings from 0 to 200 ohms.
2. Use R x 100 for resistance readings from 200 to 20,000 ohms.
3. Use R x 10,000 for resistance readings above 20,000 ohms.

Set the function switch at either – D.C. or + D.C. position. Operation is the same in either position.

Adjust ZERO OHMS control for each resistance range.

4. Observe the reading on the OHMS scale at the top of the dial. Note that the OHMS scale reads from right to left for increasing values of resistance.
5. To determine the actual resistance value, multiply the reading by the factor at the switch position. (K on the OHMS scale equals one thousand).

If there is a “forward” and “backward” resistance such as in diodes, the resistance should be relatively low in one direction (for forward polarity) and higher in the opposite direction.

## Maintenance

Rotate the function switch between the two D.C. positions to reverse polarity. This will determine if there is a difference between the resistance in the two directions.

The resistance of such diodes will measure differently from one resistance range to another on the same VOM with the function switch in a given position. For example, a diode which measures 80 ohms on the R x 1 range may measure 300 ohms on the R x 100 range. The difference in values is a result of the diode characteristic and does not indicate any fault in the VOM.

### SECTION III

#### MAINTENANCE

##### BATTERY REPLACEMENT

Two batteries are used inside the case to supply power for resistance measurements. One is a 1.5 volt D cell and the other is a 9 volt battery. When it is no longer possible to adjust the pointer to zero for the R x 1 and R x 100 ranges (see ZERO OHMS ADJUSTMENT on page 34), replace the 1.5 volt cell. When it is no longer possible to adjust the pointer to zero on the R x 10,000 range, replace the 9 volt battery.

Recommended replacement batteries are:

1.5 volt cell, NEDA 13F (Burgess No. 2 or Eveready No. 950).

9 volt battery, NEDA 1804 (Burgess 2U6 or Eveready 216).

## Maintenance

To install or replace a battery, remove the cover to the externally accessible battery compartment by loosening the single captivated screw. A small coin may be used to loosen the screw.

NOTE: When the batteries reach the end of their useful life, they should be replaced promptly. Failure to do so may result in corrosion at the battery contacts due to battery leakage.

Observe polarity when replacing the 1.5 volt D cell and connect as indicated. The D cell is held in place with spring clips which also act as battery contacts. Polarity for the D cell is marked adjacent to the battery contact clips. The 9 volt battery contacts and connector are polarized. To remove the 9 volt battery, first withdraw the battery with mated connector from the compartment. Then disconnect the connector.

## FUSE REPLACEMENT

The fuse is mounted in a holder in the externally accessible battery and fuse compartment. A spare fuse is located in a well between the + terminal of the D cell and the side of the case. Access to the compartment is obtained by loosening the single captivated screw on the compartment cover. To replace a burned out fuse, remove it from the holder and replace it only with a 1 ampere, 250 volt, quick acting type 3 AG fuse or equivalent. When removing the fuse from its holder, first remove the 9 volt battery.

## Maintenance

### CARE

Your 270-4 VOM is a very fine instrument. It has been designed to give many years of service. Give it good care and help to prolong its life by observing the following practice:

1. Keep the instrument in a horizontal position when storing and away from the edge of a workbench, shelf or other areas where it may be knocked off and damaged.
2. Avoid rapid or extreme temperature changes.
3. Avoid overloading the measuring circuits of the instrument. Develop a habit of checking the range position before connecting the test leads to a circuit.
4. Place the range switch in the TRANSIT position when the instrument is not in use or when being moved. The indicating instrument is damped in the TRANSIT position to reduce swinging of the pointer when the 270 is carried.
5. If the 270 has not been used for a long period of time, rotate the function and range switches in both directions to wipe the switch contacts for good electrical contact.
6. The instrument may be protected by one of three carrying cases. These can be obtained through your local electronic parts distributor.

## Maintenance

PART NO.	DESCRIPTION
00549	Utility Vinyl Case
01818	Leather Case
00805	Ever-Ready Leather Case

### HOW TO OPEN THE CASE

To gain access to the inside of the case for replacement of parts, remove the four screws in the bottom of the case. Two of the screws can be reached only by first removing the cover from the battery compartment. After removing the screws lift the case from the panel. When replacing the case, be certain that the wires leading to the battery compartment are seated in their respective slots in the compartment wall. This will prevent damage to the wire insulation during mating of panel and case.

## MAINTENANCE

### PARTS LIST

Reference Symbol	Description	Simpson Part No.
R-1	Rheostat, 200K Ohms	1-110193
R-2	Rheostat, 5K Ohms	5-112917
R-3	Resistor, 15K Ohms	5-115082
R-4	Resistor, 45K Ohms	1-117148
R-5	Resistor, 150K Ohms	1-117149
R-6	Resistor, 800K Ohms	1-117147
R-7	Resistor, 4 megohms	1-117151
R-8	Resistor, 5 megohms	1-118181
R-9	Resistor, 7.5 megohms	5-115081
R-10	Resistor, 2.5 megohms	5-115080
R-11	Resistor, 0.025 Ohm Shunt 10A. (Calibrate in VOM)	3-811793
R-12	Resistor, 0.468 Ohm (Bobbin)	10-675254
R-13	Resistor, 2 Ohms (Bobbin)	10-805077
R-14	Resistor, 22.5 Ohms (Bobbin)	10-805076
R-15	Resistor, 238 Ohms	5-115079
R-16	Resistor, 11.2 Ohms (Bobbin)	10-805073
R-17	Resistor, 1.109K Ohms	5-115083
R-18	Resistor, 123.57 Ohms	5-115086
R-19	Resistor, 17.55K Ohms	5-115084
R-20	Resistor, 113.77K Ohms	5-115085
R-21	Potentiometer, 11.25K Ohms	5-115263
R-22	Rheostat, 5K Ohms	1-116254
R-23	Resistor, 4K Ohms	1-117140
R-24	Resistor, 4K Ohms	1-117140
R-25	Rheostat, 5K Ohms	1-116254

## Maintenance

Reference Symbol	Description	Simpson Part No.
R-26	Resistor, 7.5K Ohms	1-117152
R-27	Resistor, 37.5K Ohms	1-117145
R-28	Resistor, 200K Ohms	1-117146
R-29	Resistor, 1 megohm	1-117150
R-30	Resistor, 1.25 megohms	5-110455
C-1	Capacitor, .1 uF, 400 V.	1-113733
D-1	Diode, Germanium	1-110722
D-2	Diode, Germanium	1-110722
V-1	Varistor, Silicon	1-110670
F-1	Fuse, 1 Amp, 250 V. 3 AG (1-1/4" x 1/4") Quick Acting	1-112507
Knobs:		
	For Function Switch	1-115789
	For Zero Ohms Adjust	1-115790
	For Range Switch (less set screw) (less Set Screw)	3-260180
	Set Screw (For Knob 3-260180)	1-114178

## Maintenance

### PARTS LIST

Description	Simpson Part No.
Case Assembly, Phenolic, Complete, (including handle less Battery Compartment Cover)	10-861725
Battery Compartment Cover Assembly for case	10-861724
Carrying Handle for case	10-860158
Rubber Bumper Plug	5-115039
270-4 Indicating Instrument with Panel Assembly	D-13823
Cover Assembly for Indicating Instrument	0-005674
Combination Probe Tip Leads, one red and one black, with removable alligator clips	00115
Crocodile Clip Test Leads, one red and one black	07500

## SECTION IV ACCESSORIES

### D.C. HIGH VOLTAGE PROBES (20,000 ohms per volt)

- 10,000 volts D.C. .... No. 00507
- 25,000 volts D.C. .... No. 00508
- 50,000 volts D.C. .... No. 00509

#### GENERAL DESCRIPTION

The D.C. high voltage probes extend the range of a 20,000 ohms per volt multimeter in a safe, convenient manner at nominal cost. Their primary purpose is the measurement of terminal potential of high voltage, low power, direct current sources. Examples are anode supplied in television receivers and other cathode ray tube circuitry.

**CAUTION:** Do not use on electrical equipment that can deliver high power under short-circuit conditions such as from a large D.C. motor-generator set.

The probe body is made of high temperature polystyrene to provide high dielectric strength and low leakage. It contains a high megohm precision resistor.

A shielded cable and internal probe shield protect the operator from any flash-over and to ground any electrostatic charge that might accumulate on the probe body.

The shielded cable and internal probe shield are connected to the ground return lead by a flexible copper braid between the two elbow connectors. A ground return lead 48 inches long with an insulated clip completes the test lead set. No additional wires are needed.

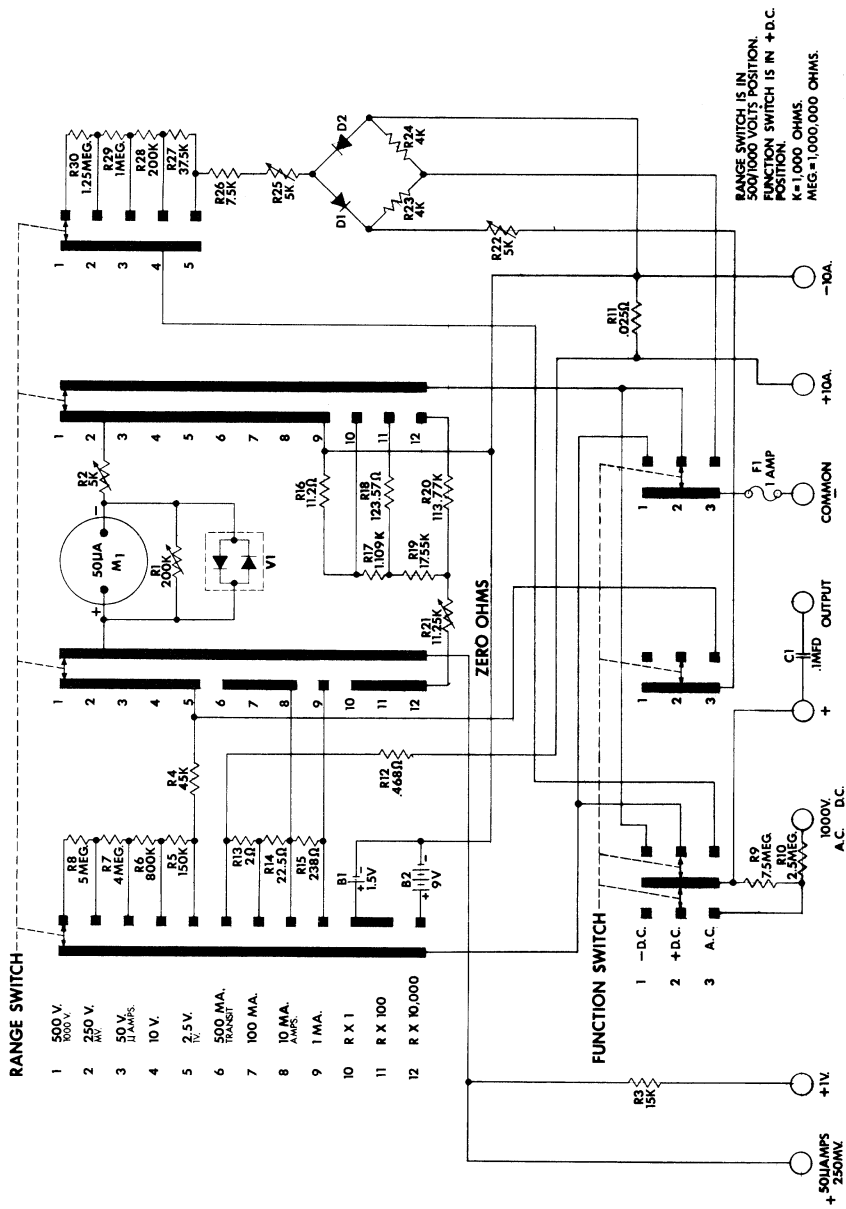

FIG. 10 SCHEMATIC DIAGRAM

**ELECTRICAL SPECIFICATIONS**

The D.C. high voltage probes are designed for use with the Simpson 270 Series 4 or any 20,000 ohms per volt VOM having a 2.5 volt D.C. range and scale graduations from 0-10 or multiple thereof for the 10 KV probe, 0-25 or multiple thereof for the 25 KV probe and 0-50 or multiple thereof for the 50 KV probe.

Accuracy:

Probe Resistance  $\pm 2\%$

The D.C. high voltage test probes are available at your local electronic parts distributor. Instructions are furnished with each high voltage probe.

**A.C. HIGH VOLTAGE PROBE  
(5,000 ohms per volt)**

10,000 volts A.C. . . . . . No. 00161

**GENERAL DESCRIPTION AND  
ELECTRICAL SPECIFICATIONS**

The 10,000 volts A.C. probe is similar to the high voltage D.C. probes with the following exceptions: The A.C. high voltage probe is designed primarily to extend the range of a 5,000 ohms per volt V.O.M. The probe is used with the instrument in the 10 volt A.C. position. Read the 0-10 volt A.C. scale and multiply by 1000.

**CAUTION:** Do not use on electrical equipment that can deliver high power under short-circuit conditions such as from a power distribution transformer.

**AMP-CLAMP MODEL 150**

The Simpson Amp-Clamp Model 150 allows A.C. current measurements without breaking the circuit under test. The Amp-Clamp works in effect as a transformer containing a split core for accommodating the conductor which carries the current being measured.

The current carrying conductor becomes the transformer primary and a coil in the Amp-Clamp serves as the secondary winding. The Amp-Clamp output voltage is proportional to the current measured and can be applied to the 270 as an A.C. voltage.

The Amp-Clamp has a range selector with 6 positions. Any of the following current ranges can be used with the 270:

5, 10, 25, 100 or 250 amperes.

1. Set the function switch of the 270 to A.C. and the range switch to 2.5 V.
2. Set the current range selector on the Amp-Clamp to a range which covers the probable current being measured.
3. Connect the Amp-Clamp leads to the -COMMON and + jacks of the 270.
4. Open the jaws of the Amp-Clamp and place around the conductor whose current is to be measured.
5. The current range to which the Amp-Clamp range switch is set expresses the A.C. current flowing in



### Applications

the circuit under test with full scale deflection of the 270. The reading observed on the 270 can be converted directly to the current measured by any of the Amp-Clamp ranges. Multiply the reading on the 2.5 V.A.C. ONLY scale of the 270 by the factor indicated on the Amp-Clamp instruction plate. The factors are also listed below:

Best Current Range Selected on Amp-Clamp	Multiply Reading by Factor:
5 Amperes	2
10 Amperes	4
25 Amperes	10
50 Amperes	20
100 Amperes	40
250 Amperes	100

### SECTION V

#### APPLICATIONS

##### GENERAL

The Simpson Volt-Ohm-Milliammeter 270 Series 4 is designed to measure almost all characteristics of electrical and electronic circuits. It is the most versatile piece of test equipment that you can own.

Specific applications in measuring voltage, current and resistance are found in the booklet "1001 Uses for the 260 Volt-Ohm-Milliammeter" which is available at your electronic parts distributor.

### SIMPSON WARRANTY REPAIR STATIONS AND PARTS DEPOTS

Alabama, Huntsville 35805 Electro Tech, Inc. 106 Jordan Lane N.W.	Area Code 205 539-1250
Arizona, Phoenix 85034 Kierulff (Metermaster) 2633 E. Buckeye	Area Code 602 273-7331
California, Glendale 91201 JSD Engineering Company 6915 San Fernando Road	Area Code 213 840-6187
California, Los Angeles 90022 Metermaster/Los Angeles 5646 Jellson St.	Area Code 213 685-4340
California, Palo Alto 94303 Kierulff/Metermaster 3969 E. Bayshore Road	Area Code 415 968-6292
California, San Diego 92111 Metermaster/Kierulff 8796 Balboa Ave.	Area Code 714 278-2112
California, San Francisco 94105 Pacific Electrical Instrument Lab. 111 Main Street	Area Code 415 421-7185
Colorado, Denver 80209 Meter Master Instrument Service 748 South Broadway	Area Code 303 722-5766
Connecticut, Middletown The Mancib Co. Randolph Road and Coe	Area Code 203 347-5629
Connecticut, New Haven 06511 Kaufman Instrument Lab. 810 Dixwell Avenue	Area Code 203 776-7201
Florida, Miami 33136 Florida Precision Instrument Corp. 800 N.W. 7th Avenue	Area Code 305 374-1731
Florida, Orlando 32806 Electro Tech, Inc. 307 - 27th Street	Area Code 305 423-5589
Georgia, Hapeville 30054 Electro Tech, Inc. 3020 Commerce Way	Area Code 404 767-8761

Hawaii, Honolulu 96819 Electronic Measurement Corp. 2979 Ualena Street	870-700	Missouri, St. Louis 63142 Scherrer Instruments 7170 Manchester	Area Code 314 644-5362
Illinois, Chicago 60648 A & M Instrument, Inc. 6251 W. Touhy	Area Code 312 774-3500	New Jersey, Belleville 07109 Marshall Instruments, Inc. 236 Washington Avenue	Area Code 201 751-1190
Illinois, Chicago 60644 Pacific Indicator Company 5924 West Madison Street	Area Code 312 261-1330	New Jersey, Roselle 07203 E. T. Instrument & Controls 205 Columbus Ave.	Area Code 201 241-8282
Kansas, Wichita 67211 Main Electronics, Inc. 363 Pattie	Area Code 316 267-3581		
Louisiana, New Orleans 70115 Industrial Instrument Works 3305 Tchoupitoulas Street	Area Code 504 895-5621	New York, Buffalo 14216 Electrical Instrument Labs. 932 Hertel Avenue	Area Code 716 876-0880
Maryland, Elkridge 21227 Sunshine Scientific Instrument 5600 Main St.	Area Code 301 796-5600	New York, Great Neck, L.I. 11022 A & M Instrument, Inc. Community Drive	Area Code 516 487-0330
Maryland, Beltsville 20705 Meter Devices 11325 Maryland Ave.	Area Code 301 345-7775	New York, Great Neck, L.I. 11022 Simpson Instrument Sales & Service 130 Cutter Mill Road	Area Code 212 683-0674
Maryland, Timonium 21093 E. I. L. Instrument Div. 110 W. Timonium Road	Area Code 301 252-1260	New York, New York 10011 E. T. Instrument & Control Co. 85 Tenth Avenue	Area Code 212 675-2400
Massachusetts, Burlington 01803 The Mancib Company Middlesex Turnpike at "A"	Area Code 617 272-9450	New York, New York 10013 Nilsson Electronic Labs 103 Lafayette Street	Area Code 212 WA 5-1730
Massachusetts, Needham Heights 02194 Instruments, Inc. 570 Hillside Avenue	Area Code 617 444-9410	New York, Syracuse 13215 Syracuse Instrument Laboratories 4895 South Avenue	Area Code 315 492-1651
Michigan, Ferndale 48220 Ram Meter, Inc. 1100 Hilton Road	Area Code 313 547-1000	New York, Vestal 13850 Compton Industries, Inc. 413 Commerce Road	Area Code 607 729-9221
Minnesota, Minneapolis 55427 Instrumentation Services 957 Winnetka Ave.	Area Code 612 544-8916	North Carolina, Charlotte 28206 Electro Tech, Inc. 5141 Belhaven Blvd.	Area Code 704 392-7451

Ohio, Cleveland 44103  
Pioneer-Standard Electronics, Inc.  
5403 Prospect Avenue

Area Code 216  
432-0010

Ohio, Cleveland 44135  
Weschler Electric Corp.  
4250 West 130th Street

Area Code 216  
251-4609

Ohio, Dayton 45404  
Srepcu Electronics Div.  
314 Leo Street

Area Code 513  
224-0871

Oklahoma, Tulsa 74120  
Agra Engineering Company  
551 S. Quaker

Area Code 918  
582-5754

Oregon, Portland 97217  
Westcon, Inc.  
1910 Killingsworth Street

Area Code 503  
285-6629

Pennsylvania, Monroeville 15235  
E. I. L. Instrument Div.  
2366 Holliday Park Shopping Center

Area Code 412  
327-4450

Pennsylvania, Philadelphia 19115  
Sunshine Scientific Instrument  
1810 Grant Avenue

Area Code 215  
673-5600

Tennessee, Memphis 38104  
Instrument Repair Service  
206 South Cleveland

Area Code 901  
278-0762

Texas, Dallas 75204  
Ultra Instrument Lab., Inc.  
3515 Swiss Avenue

Area Code 214  
826-6395

Texas, Houston 77003  
Electrical Instrument & Meter Co.  
369 M & M Building

Area Code 713  
227-6252

Washington, Seattle 98105  
Eicher-Richards  
2727 N.E. Blakeley St.

Area Code 206  
523-7888

Washington, Seattle 98119  
The Instrument Lab., Inc.  
934 Elliott Avenue West

Area Code 206  
283-5850

Wisconsin, Milwaukee 53202  
The Electro-Mechano Company  
241 East Erie Street

Area Code 414  
272-4050

## New **SOLID-STATE FET-INPUT MULTIMETER**

from  
**SIMPSON**  
of course

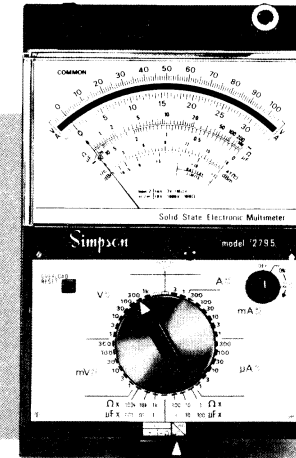

**PORTABLE,  
LABORATORY  
ACCURACY,  
SOLID-STATE  
ELECTRONIC  
MULTIMETER**

❖ **68 Switch Selectable Functions:**

- 13 AC and DC Voltage Ranges (as low as 1 MV, full scale)
- 14 AC and DC Current Ranges (as low as 1  $\mu$ A, full scale)
- 6 low power (IC compatible) Resistance Ranges
- 6 completely self-contained Capacitance Ranges

❖ **Plus 12 Output Ranges**

- ❖ Circuit Breaker Overload Protection
- ❖ High FET-Input Impedance
- ❖  $\pm 1\%$  Accuracy for AC and DC
- ❖ Negligible Voltage Drop
- ❖ Simple, Straight-Forward Operation
- ❖ Size: 8.07" High, 5.04" Wide, 3.94" Deep. Only 3.3 lbs.

**2795 MULTIMETER** supplied complete with batteries, test leads and operator's manual. Complete accessories available.

WRITE FOR BULLETIN L-1010 . . . OR CONTACT  
YOUR SIMPSON INSTRUMENTATION PRODUCTS  
DISTRIBUTOR FOR OFF-THE-SHELF DELIVERY

**Simpson**  
EQUIPMENT'S THAT MEAN ACCURATE



**SIMPSON ELECTRIC COMPANY**  
5200 W. Kinzie Street, Chicago, Illinois 60644  
Phone (312) 379-1121  
EXPORT DEPT.: 400 W. Madison St, Chicago, Ill 60606. Cable Simelco  
IN CANADA: Bach-Simpson Ltd., London, Ontario  
IN INDIA: Ruttonsha-Simpson Private Ltd., International House,  
Bombay-Agra Road, Vikhroli, Bombay

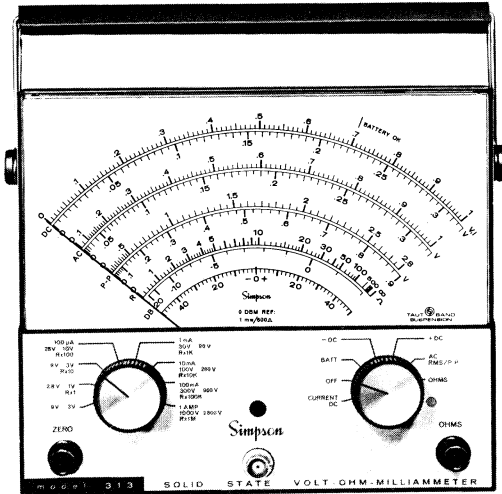

## Simpson's NEW solid-state VOM with FET-Input

- HIGH INPUT IMPEDANCE...  
11 Meg  $\Omega$  DC 10 Meg  $\Omega$  AC
- PORTABLE..... battery operated
- 7-INCH METER..... overload protected

Simpson's new 313 gives you high input impedance for accurate testing of latest circuit designs... free of line cord connections. Over 300 hours operation on inexpensive batteries. And the new 313 is *stable*, which means positive, simplified zero and ohms adjustments. Protected FET-input handles large overloads. DC current ranges to 1000 mA. Sensitive Taut Band movement and 7-inch meter scale provide superior resolution down to 5 millivolts. Write today for complete specifications.

Complete with batteries, 3-way AC-DC-Ohms probe and operator's manual

GET "OFF-THE-SHELF" DELIVERY FROM  
YOUR LOCAL ELECTRONIC DISTRIBUTOR

# Simpson

ELECTRIC COMPANY



5200 W. Kinzie Street, Chicago, Illinois 60644 • Phone (312) 379-1121  
EXPORT DEPT - 400 W. Madison Street, Chicago, Illinois 60606. Cable Simelco  
IN CANADA - Bach Simpson Ltd., London, Ontario • IN INDIA - Ruttonsha-Simpson Private  
Ltd., International House, Bombay-Agra Road, Vikhroli, Bombay

## Warranty

SIMPSON ELECTRIC COMPANY warrants each instrument and other articles of equipment manufactured by it to be free from defects in material and workmanship under normal use and service, its obligation under this warranty being limited to making good at its factory any instrument or other article of equipment which shall within 90 days after delivery of such instrument or other article of equipment to the original purchaser be returned intact to it, or to one of its authorized service stations, with transportation charges prepaid, and which its examination shall disclose to its satisfaction to have been thus defective; this warranty being expressly in lieu of all other warranties expressed or implied and of all other obligations or liabilities on its part, and SIMPSON ELECTRIC COMPANY neither assumes nor authorizes any other persons to assume for it any other liability in connection with the sale of its products.

This warranty shall not apply to any instrument or other article of equipment which shall have been repaired or altered outside the SIMPSON ELECTRIC COMPANY factory or authorized service stations, nor which has been subject to misuse, negligence or accident, incorrect wiring by others, or installation or use not in accord with instructions furnished by the manufacturer.

# Simpson

**ELECTRIC COMPANY**

5200 W. Kinzie Street, Chicago, Illinois 60644

Phone: (312) 379-1121

Export Dept.: 400 W. Madison Street, Chicago, Illinois 60606, Cable, Simelco

IN CANADA: Bach Simpson Ltd., London, Ontario

IN INDIA: Ruttonsha Simpson Private Ltd., International House, Bombay

IN INDIA: Ruttonsha Simpson Private Ltd., International House, Bombay, Vikhroli, Bombay



DIVISION