

new VOMs  
from **Simpson**

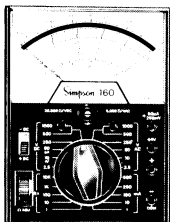

### 160 Handi-VOM

- Just 3<sup>3</sup>/<sub>16</sub>" Wide . . .  
with Full-Size VOM Features
- 20,000  $\Omega$ /VDC . . . 5,000  $\Omega$ /VAC
  - $\pm 2\%$  DC . . .  $\pm 3\%$  AC
  - 5 Resistance Ranges . . . Plus a 0.100 DC Millivolt Range

### 314 Solid-State VOM

- VTVM Features . . . VOM Conveniences
- 10mVAC, 50mVDC ranges
  - Low power and conventional ohms
  - Frequency compensated, 100 Meg $\Omega$  probe
  - Large 7" scale
  - Battery Operated

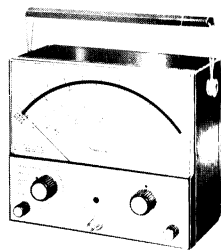

*Write for Catalog 4500*

**Simpson** has over 1,400 stock  
sizes and types of panel instruments, too!



*Write for Catalog 4500*

# OPERATOR'S MANUAL

## MODEL 390-2 VOLT-AMP-WATTMETER

**SIMPSON ELECTRIC COMPANY**

853 Dundee Ave., Elgin, Illinois 60120

Area Code 312, Telephone 697-2260

In Canada, Bach-Simpson, Ltd., London, Ontario

Courtesy of [Simpson260.com](http://Simpson260.com)

& Instrument Meter Specialties - [MeterSales.com](http://MeterSales.com)

Printed in U.S.A.  
8-76 Hinz

Part No. 5-118348

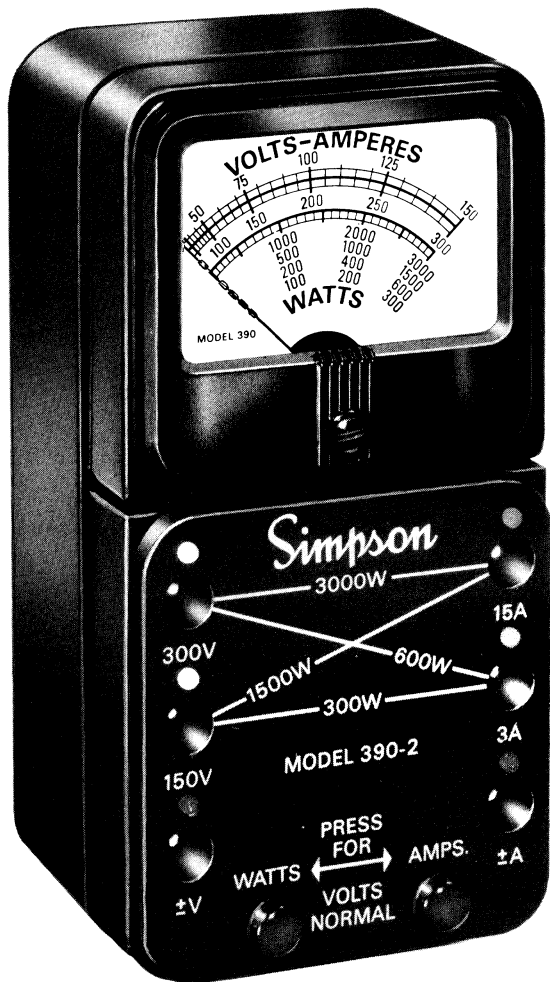

Figure 1-1. Model 390-2 Volt-Amp-Wattmeter

## TABLE OF CONTENTS

<b>SECTION I</b>	
<b>Introduction</b> .....	1-1
1.1 General .....	1-1
1.2 Description .....	1-1
1.3 Technical Data .....	1-2
<b>SECTION II</b>	
<b>Installation</b> .....	2-1
2.1 Unpacking and Inspection .....	2-1
2.2 Power Source Requirements .....	2-1
2.3 Installation .....	2-1
<b>SECTION III</b>	
<b>Controls, Connectors and Indicator</b> .....	3-1
3.1 General .....	3-1
3.2 Description .....	3-1
<b>SECTION IV</b>	
<b>Operation</b> .....	4-1
4.1 General .....	4-1
4.2 Safety Precautions .....	4-1
4.3 Zero Setting of Meters .....	4-2
4.4 Input Lead Connections .....	4-3
4.5 DC Voltage Measurements, 0-150V, 0-300V .....	4-3
4.6 AC Voltage Measurements, 0-150V, 0-300V .....	4-3
4.7 AC Current Measurements 0-3A, 0-15A .....	4-5
4.8 AC Watts 0-300, 0-1500, Using Break-In Plug .....	4-7
4.9 AC Watts 0-600, 0-3000, Using Break-In Plug .....	4-8
4.10 Determining Power Factor .....	4-9
4.11 Use of Wattmeter With Two and Three Phase Circuits .....	4-9
4.12 Troubleshooting .....	4-10
<b>SECTION V</b>	
<b>Theory of Operation</b> .....	5-1
5.1 AC and DC Voltmeter Circuit .....	5-1
5.2 AC Ammeter Circuit .....	5-1
5.3 AC Wattmeter Circuit .....	5-3
5.4 Schematic Diagram .....	5-3
5.5 Break-In Plug .....	5-3

## SECTION VI

Maintenance .....	6-1
6.1 General .....	6-1
6.2 Warranty .....	6-1
6.3 Shipping .....	6-1
6.4 Care .....	7-1

## SECTION VII

Ordering Information, Schematic Diagram And Authorized Service Centers .....	7-1
7.1 General .....	7-1

## LIST OF TABLES

1-1 Technical Data .....	1-2
3-1 Controls, Connectors and Indicator .....	3-1
7-1 Instrument and List of Items Furnished .....	7-1
7-2 Replacement Parts List .....	7-1

## LIST OF ILLUSTRATIONS

1-1 Model 390-2 Volt-Amp-Wattmeter .....	ii
3-1 Controls, Connectors and Indicator .....	3-2
4-1 Break-In Plug Connections, 150V, 3A and 300W Ranges .....	4-4
4-2 Model 390-2 and Special Test Lead Set Application .....	4-5
4-3 Break-In Cable Assembly and Cable Adapter Set .....	4-8
4-4 Connections for Measurement in Single, Two and Three Phase AC Three-Wire Circuits .....	4-11
5-1 Simplified Voltmeter Circuit .....	5-1
5-2 Simplified AC Ammeter Circuit .....	5-2
5-3 Simplified Wattmeter Circuit, 300 Watt Range .....	5-2
5-4 Cross Section of Break-In Plug, Showing Cable Connections .....	5-3
7-1 Model 390-2, Schematic Diagram .....	7-2

### WARNING

**This instrument is designed to prevent accidental shock to the operator when properly used. However, no engineering design can render safe an instrument which is used carelessly. Therefore, this manual must be read carefully and completely before making any measurements. Failure to follow directions can result in a serious or fatal accident.**

**SHOCK HAZARD:** As defined in American National Standard, C39.5, Safety Requirements for Electrical & Electronic Measuring & Controlling Instrumentation, a shock hazard shall be considered to exist at any part involving a potential in excess of 30 volts rms (sine wave) or 42.4 volts DC or peak and where a leakage current from that part to ground exceeds 0.5 milliampere, when measured with an appropriate measuring instrument defined in Section 11.6.1 of ANSI C39.5.

**NOTE:** The proper measuring instrument for the measurement of leakage current consists essentially of a network of a 1500 ohm non-inductive resistor shunted by a 0.15 microfarad capacitor connected between the terminals of the measuring instrument. The leakage current is that portion of the current that flows through the resistor. The Simpson Model 229-Series 2 AC Leakage Current Tester meets the ANSI C39.5 requirements for the measurement of AC leakage current and can be used for this purpose. To measure DC Leakage current, connect a 1500 ohm non-inductive resistor in series with a Simpson 0-500 DC microammeter and use this as the measuring instrument.

# SECTION I

## INTRODUCTION

### 1.1 GENERAL

The Simpson Model 390-2 Volt-Amp-Wattmeter as shown in Figure 1-1 (hereafter referred to as the Model 390-2 or as the Instrument), has an AC voltmeter, DC voltmeter, AC ammeter and AC wattmeter all in one compact, convenient instrument.

### 1.2 DESCRIPTION

**1.2.1** This highly versatile Instrument is extremely rugged and of the highest quality construction. The full size three-inch meter is of the dynamometer type with a moving coil armature operating within two field coils. The readings are clearly marked on two arcs of the scale; one for volts and amperes and one for watts. An unusual and practical feature is the uniform wattmeter scale of equal divisions which permit more accurate readings.

**1.2.2** A special break-in plug and lead assembly simplifies making connections to cord connected devices. Also, the Instrument can be used with special test leads when the break-in plug is not used (see Table 7-2). The panel designations make the connections for the various ranges apparent at a glance. All markings are screened on the panel with epoxy white enamel for maximum legibility. The ammeter connectors are identified with a red dot and the voltmeter connectors have a white dot.

**1.2.3** The accuracy of the Model 390-2 is 5% or better of full scale reading. The errors due to phase angle and frequency are so small that they can be disregarded within the normal frequency range of 50 to 133 Hz. Approximately 2%

### Introduction

should be added to the readings obtained with 25 Hz current. The current loss in the Model 390-2 is very low and has no appreciable effect on the readings.

### 1.3 TECHNICAL DATA

Table 1-1 lists the technical data for the Simpson Model 390-2 Volt-Amp-Wattmeter.

**Table 1-1. Technical Data**

<b>1. DC VOLTS:</b>	
Ranges:	0-150 and 0-300 volts
Resistance:	Approximately 50 ohms/volt
Accuracy:	5% of full scale
<b>2. AC VOLTS:</b>	
Ranges:	0-150 and 0-300 volts
Resistance:	Approximately 50 ohms/volt
Accuracy:	5% of full scale
<b>3. AMPERES (AC only):</b>	
Ranges:	0-3 and 0-15 amperes
Voltage Drop:	Approximately 0.5 volts
Accuracy:	5% of full scale
<b>4. WATTS (AC only):</b>	
Ranges	
(150 VAC):	0-300 and 0-1500 watts
(300 VAC):	0-600 and 0-3000 watts
Phase Error:	Negligible at 60 Hz, 2% at 25 Hz
Accuracy:	5% of full scale
<b>5. FREQUENCY RESPONSE:</b>	50-133 Hz, no correction required 25 Hz, add 2% to reading
<b>6. METER SIZE:</b>	3 inches
<b>7. DIMENSIONS:</b>	
Height:	5-7/8" (149mm)
Width:	3" (76mm)
Depth:	2-1/2" (64mm)
<b>8. WEIGHT:</b>	2-1/2 lbs. (1.13Kg)

## SECTION II

### INSTALLATION

#### 2.1 UNPACKING AND INSPECTION

**2.1.1** Examine the shipping carton for obvious signs of damage before unpacking. If shipping carton is in good condition, unpack and inspect the Instrument for possible damage incurred during shipment. If damage is noted, notify the carrier and supplier and do not attempt use of the Instrument. If the Instrument appears to be in good condition, read Operator's Manual in its entirety. Become familiar with the Instrument as instructed in the manual, then check the electrical performance.

**2.1.2** Save the shipping carton and packing materials for future storing or shipping of the Instrument.

#### 2.2 POWER SOURCE REQUIREMENTS

No supply source is required. The Instrument is energized by the circuit being measured.

#### 2.3 INSTALLATION

The Instrument can be set horizontally or vertically, however, maximum accuracy will be assured in the horizontal position.

## SECTION III

### CONTROLS, CONNECTORS AND INDICATOR

#### 3.1 GENERAL

All operating controls, connectors and indicator are shown in Figure 3-1. Become thoroughly familiar with each before operating the Instrument for the first time.

#### 3.2 DESCRIPTION

Description of the controls, connectors and indicator are listed in Table 3-1. The item call-outs in Figure 3-1 correspond with the numerical order of the items listed in Table 3-1.

Table 3-1. Controls, Connectors and Indicator

<b>1. 15 Amp Jack (red dot):</b>	Load side of current coil for 15 Amp range. Also common for 1500-3000 watt range wattmeter connection.
<b>2. 3 Amp Jack (red dot):</b>	Load side of current coil for 3 amp range. Also common for 300-600 watt range wattmeter connection.
<b>3. <math>\pm</math> Current Jack (black dot):</b>	Source side of current coil.
<b>4. AMPS Push-button:</b>	When depressed, provides an AC current indication in amperes on the meter, if a load is connected.
<b>5. WATTS Push-button:</b>	When depressed, provides an AC power consumption indication in watts on the meter, if a load is connected.
<b>6. <math>\pm</math> Voltage Jack (black dot):</b>	Voltage coil connection to one side of power line.
<b>7. 150 VOLTS Jack (white dot):</b>	Voltage coil connection for 150 volt range. Also common for 300-1500 watt range wattmeter connector.

## Controls, Connectors, and Indicator

8. **300 VOLTS Jack (white dot):** Voltage coil connection for 300 volt range. Also common for 600-3000 watt range wattmeter connection.
9. **Zero Adjust:** Mechanically sets the meter pointer to zero with the Instrument disconnected.
10. **Meter:** Provides readings on two scale arcs, one for volts and amperes, and one for watts.
11. **Break-in Cable Assembly:** Facilitates connections to cord connected devices. See paragraph 4.4 for special test lead set with alligator clips.

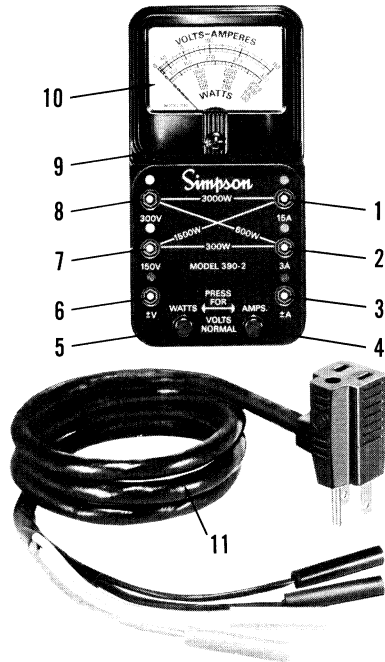

Figure 3-1. Controls, Connectors and Indicator

## SECTION IV

### OPERATION

#### WARNING

All power line circuits contain voltages constituting a shock hazard that can be lethal (refer to Shock Hazard definition on page v). This Instrument was designed to prevent accidental shock to the operator. However, exceeding its capabilities, or using it carelessly can be dangerous. Review the Safety Precautions listed below. Insure that you understand them, and observe them when using this Instrument.

#### 4.1 GENERAL

This section of the manual contains all the information related to operation of the Instrument. Special notes and instructions also have been included for added safety and convenience.

#### 4.2 SAFETY PRECAUTIONS

**4.2.1** The Model 390-2 is intended for use only by personnel qualified to recognize shock hazards and trained in the safety precautions required to avoid possible injury. Refer to the "SHOCK HAZARD" definition on page v.

**4.2.2** Do not work alone when making measurements where a shock hazard might exist. Notify a nearby person that you are making, or intend to make such measurements.

**4.2.3** Locate all voltage sources and accessible current paths prior to making circuit connections. Be sure the equipment being tested is properly grounded (if that is its normal mode of operation), and that its fuse(s) are of the correct type and rating. Make certain the test leads are connected to the proper input jacks before applying power.

## Operation

**4.2.4** Check the work environment. The work area, as well as hands and shoes must be dry.

**4.2.5** Avoid making tests and measurements under humid, damp, or other environmental conditions that could affect the dielectric withstanding voltage of the test equipment.

**4.2.6** Do not touch "live circuits" or any object that could provide a current path to the common side of the circuit under test or power line ground.

**4.2.7** Use a 3-wire power line outlet that is correctly wired in accordance with the latest National Electrical Code. If you are not certain that the power outlet meets these requirements, use a 3-wire to 2-wire adapter plug, and ground the wire from the adapter to a known good earth ground.

**4.2.8** When using the special test lead set without the break-in plug, shut off the power to the circuit before making clip connections.

**4.2.9** When testing a 240-VAC line operated device, make up a 120-240 VAC adapter set as shown in Figure 4-4. Be sure the outlet used is correctly wired as discussed in paragraph 4.2.7.

## 4.3 ZERO SETTING OF METERS

- a. Before you use your Instrument, be sure that the pointer is on zero when there is no power applied. A zero adjust screw is located directly below the meter scale (refer to Figure 3-1).
- b. Use a screwdriver to rotate the screw either clockwise or counterclockwise until the knife-edged pointer rests over the zero indication at the left hand side of the scale.

## Operation

## 4.4 INPUT LEAD CONNECTIONS

**4.4.1** Always make the connections to the Model 390-2 in accordance with the directions given in the following paragraphs prior to making connections to the power source.

**4.4.2** When testing line operated devices, always use the Break-in Cable Assembly supplied with the Instrument (refer to Figure 4-1). Make up a cable adapter set for use on 240 VAC line operated devices (refer to Figure 4-3).

**4.4.3** In cases when it is not convenient to use the Break-in Cable Assy., the special test lead set (see Table 7-2) can be used. For line voltages up to 150 volts, connect the  $\pm V$  and the 150V jacks across the line and the  $\pm A$  and the 3A or 15A jacks in series with the load for 300 and 1500 watt ranges respectively. The leads are color coded to match the colored dots of the respective jacks (see Figure 4-2). For line voltages between 150 and 300 volts, connect the  $\pm V$  and the 300V jacks across the line, and the  $\pm A$  and the 3A or 15A jacks in series with the load for the 600 and 3000 watt ranges respectively.

## 4.5 DC VOLTAGE MEASUREMENTS 0-150V, 0-300V

The voltmeter may be used to measure DC voltages, but NOT DC current or power. For measuring DC voltages, follow the same procedure as for AC voltage measurement, as discussed in the following paragraph.

## 4.6 AC VOLTAGE MEASUREMENTS, 0-150V, 0-300V

- a. Connect the leads from the Break-in Plug Assembly according to color as shown in Figure 4-1. Connect the white lead to the jack marked 150V when testing 120 volt devices, or to the jack marked 300V when testing 240 volt devices.

## Operation

- b. Insert the Break-in Plug into the outlet of the AC line to be measured. See paragraph 4.4 for 240 volt line measurement, or use of special test leads.
- c. Read the voltage on the top arc of the meter scale, using the figures 0-150 for the 150V range and 0-300 for the 300V range. The first heavy line above zero represents 25 on the 0-150 range and 50 on the 0-300 range. When the object under test is plugged into the Break-in Plug, the voltmeter will indicate if there is a voltage drop in the line. The voltmeter can also be used to indicate voltage drop between no load and full load operation.

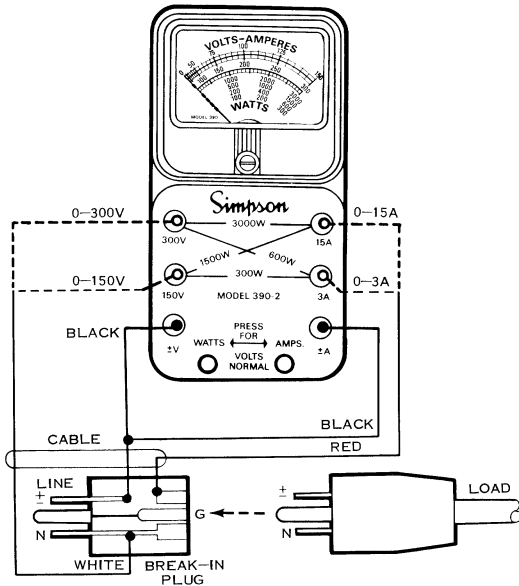

Figure 4-1. Break-In Plug Connections, 150V, 3A and 300V Ranges

## Operation

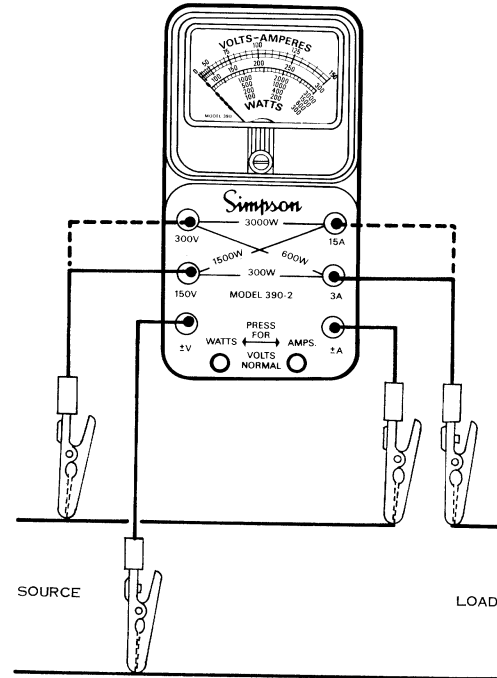

Figure 4-2. Model 390-2 and Special Test Lead Set Application

## 4.7 AC CURRENT MEASUREMENTS, 0-3A, 0-15A

NOTE: DC current will damage the Instrument transformer.

- a. Connect the leads from the Break-In plug according to color as shown in Figure 4-1. To use the 3A range, connect the red lead to the terminal marked "3A". Use the 0-300 scale and drop two zeros (divide by 100).



## Operation

- b. When the 15A range is to be used, connect the red lead to the terminal marked "15A" (use the 0-150 scale and divide by 100).

### CAUTION

**WHEN THE APPROXIMATE VALUE OF CURRENT IS UNKNOWN, ALWAYS USE THE HIGHER RANGE FIRST AS A PROTECTION TO THE METER.**

- c. Insert the Break-In Plug into 120V power outlet (in the AC line), or follow procedures as given in paragraph 4.4 for 240V power.
- d. Plug the device to be checked into the Break-In Plug as shown in Figure 4-1.
- e. Press the AMPS pushbutton.

NOTE: Failure to fully depress the AMPS pushbutton may result in an erroneous reading.

- f. Read the current value on the top arc of the scale. For the 3A range, use the figures 0-300, and drop two zeros (divide by 100). Use the black digits to indicate the decimal fraction. Repeat the procedure using the figures 0-150 for the 15A range. The first heavy line above zero represents 0.5A on the 3A range, and 2.5A on the 15A range.
- g. Special test leads can be substituted for the Break-In Plug when necessary (paragraph 4.4). Open (break) the circuit to be measured and connect the free ends of the test leads across the open circuit.
- h. Press the AMPS pushbutton to read the current.
- i. Restore the circuit continuity when test is complete.
- j. To check the load on the entire line, remove the fuse from the fuse box, or place the circuit breaker in the

## Operation

- OFF position (depending upon the equipment used).
- k. Connect the Model 390-2 as an ammeter in series with the line and the load using the Special Test Lead Set, or as a wattmeter (see Figure 4-2).
- l. To extend the current range of the Model 390-2 use a current transformer. A current transformer with a ratio of 10 to 1, when used with the 3 ampere range, will permit a reading of 30 amperes. Multiply the readings on the 3A range by 10. Current transformers with other ratios may be used in the same way if the scale readings are multiplied by the ratio of the transformer.

## 4.8 AC WATTS 0-300, 0-1500, USING BREAK-IN PLUG (line voltage 0-150)

- a. Connect the leads from the Break-In Plug according to their color as shown in Figure 4-1.

NOTE: When the red lead is connected to the 3A terminal and the white lead is connected to the 150V terminal as shown, the connecting line on the panel between the 150V and 3A terminals indicates that the 300 watt range is being used. When the red lead is connected to the 15A terminal, the range is 1500 watts, as indicated by the line on the panel between the 150V and 15A terminals.

- b. Insert the Break-In Plug into an AC outlet.
- c. Plug the device to be checked into the Break-In Plug as shown in Figure 4-1.
- d. Press the WATTS pushbutton (be sure to fully depress the pushbutton).
- e. Read watts directly on the lower arc of the scale. Use the figures corresponding to the range being used.
- f. In cases where the momentary load exceeds the limits of the 1500W range, such as the starting current of a

## Operation

motor, the red lead from the Break-In Plug may be connected to the 300V terminal and the 3000W range used.

### 4.9 AC WATTS 0-600, 0-3000, USING BREAK-IN PLUG (line voltage 0-300)

- An adapter is required to connect from 120V to 240V line (see paragraph 4.4). The Break-In Plug will not connect directly into a 240V line. Therefore, it is necessary to construct an adapter plug. Refer to Figure 4-3 for adapter make-up and test connections.
- Connect the white lead from the Break-In Plug (see Figure 4-1) to the 300V meter terminal. Connect the black leads to the  $\pm V$  and  $\pm A$  terminals.
- Connect the red lead from the Break-In Plug to the 3A terminal. The line on the panel between the 300V and 3A terminals indicates that the 600 watt range is being used. When the red wire is connected to the 15A terminal the range is 3000 watts as indicated by the line on the panel connecting the 300V and 15A terminals.
- Insert the Break-In Plug into the 240V adapter socket, and the adapter plug into a 240 VAC source.

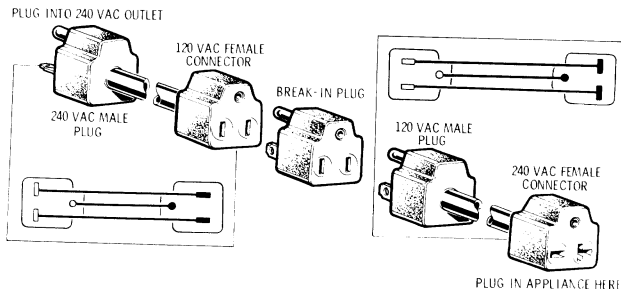

Figure 4-3. Break-In Cable Assembly and Cable Adapter Set

## Operation

- Plug the appliance to be checked into the female adapter and the male end of the adapter into the Break-In Plug.
- Press the WATTS pushbutton (be sure to press the button all the way down).

### 4.10 DETERMINING POWER FACTOR

- In an AC circuit containing only resistance, such as a toaster, the power will be approximately equal to the product of the volts and amperes. However, when the circuit contains reactance, such as a motor, the power will be less than the product of the volts and amperes because of the power factor.
- The power factor of a circuit can be determined with the Model 390-2 in the following manner: Take the voltage, current and power readings of the circuit under test. Since unity power factor results when the power is equal to the product of the volts and amperes, the power factor of the circuit under test is the ratio of the power reading on the meter to the product of the volts and amperes. For example, if the line voltage is 120, current 2.5 amperes, and power indicated by the meter is 225 watts, the power factor is equal to

$$100 \times \frac{225}{120 \times 2.5} = 75\%$$

### 4.11 USE OF WATTMETER WITH TWO AND THREE PHASE CIRCUITS

Figure 4-4 shows the connections for measuring power in a single phase, two or three phase, three-wire circuit using two Model 390-2 wattmeters. If a reading is obtained on both meters, the true power is the sum of the two readings. If the pointer of one meter deflects to the left of zero, it means that the power factor is less than 50% and the connection to the voltage terminals for that meter should be

## Operation

reversed. The reading then obtained should be subtracted from the reading of the other meter. If the power factor is exactly 50%, one meter will indicate zero. If only one Model 390-2 is available, connect it successively in the two positions as shown in Figure 4-4.

## 4.12 TROUBLESHOOTING

**4.12.1** You will find many uses for the Model 390-2 in checking line voltage, current drain and power consumption, the three simple tests which diagnose most cases of electrical trouble. High current drain and high power consumption generally indicate shorted turns in a motor, or too heavy a load or shorted sections in elements of heaters, irons, etc. This also might be indicated by an excessive drop in line voltage when the device is connected to a power outlet. A drop in line voltage may also indicate inadequate or overloaded supply lines. No current would indicate an open cord, switch or circuit in the device being checked. These same indications apply to refrigerators, oil burners, washing machines, ventilating fans, air conditioning systems, air compressors, water pumps, vacuum cleaners, heaters, irons, toasters, waffle irons, food mixers, lighting circuits, heat lamps, radios, television and also all devices which use a motor or transistorized circuitry.

**4.12.2** The wattmeter section may also be used as an indicator for the type of trouble in solid-state radios, stereo sets or television receivers. A high wattage drain would indicate a shorted transistor or improper bias while a low wattage drain would indicate an open transistor or circuit. Many manufacturers include possible clues pointing to faulty circuits with certain wattage readings.

## Operation

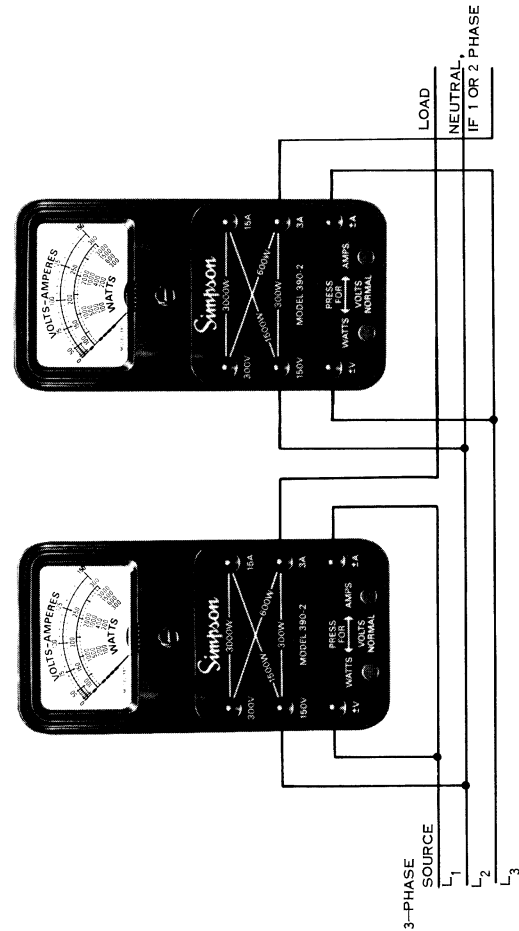

Figure 4-4. Connections for Measurement in Single, Two and Three Phase AC Three-Wire Circuits

## SECTION V

### THEORY OF OPERATION

#### 5.1 AC AND DC VOLTMETER CIRCUIT

Figure 5-1 shows the circuit used when making voltage tests. The multiplier resistors for the 150V and 300V ranges are wound to match each meter. The WATTS and AMPS pushbuttons are in the normal (out) position and the contacts of these switches completes the circuit.

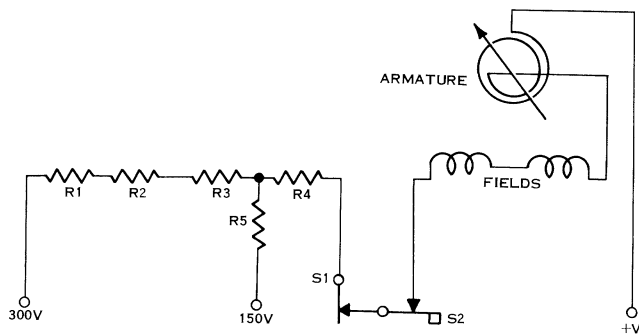

Figure 5-1. Simplified Voltmeter Circuit

#### 5.2 AC AMMETER CIRCUIT

Figure 5-2 shows the ammeter circuit used when the AMPS pushbutton is depressed. This connects the meter to transformer T1. When all turns of the primary winding are connected, the 3 ampere range is provided. The center tap provides the 15 ampere range. Resistor R6 is used for calibration.

### Theory of Operation

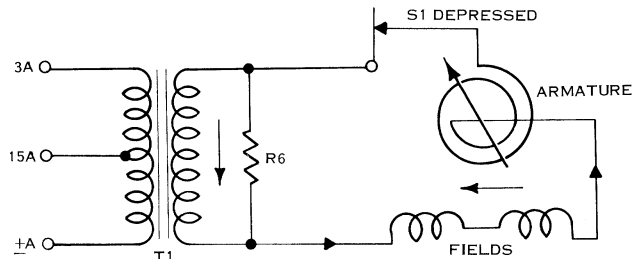

Figure 5-2. Simplified AC Ammeter Circuit

#### 5.3 AC WATTMETER CIRCUIT

Figure 5-3 shows the circuit used when the WATTS pushbutton is depressed and the Break-In Plug is connected for the 300 watt range. In this position the armature of the meter is connected across the line through a series resistor and the field coils of the meter are connected across the current transformer T1.

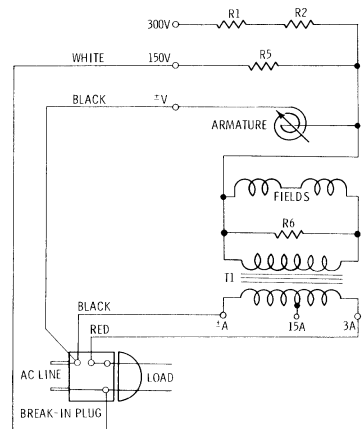

Figure 5-3. Simplified Wattmeter Circuit, 300 Watt Range

## Theory of Operation

### 5.4 SCHEMATIC DIAGRAM

The simplified circuits shown in Figures 5-1, 5-2 and 5-3 together with the AMPS and WATTS pushbuttons, are combined in the complete schematic diagram shown in Figure 7-1.

### 5.5 BREAK-IN PLUG

The special Break-In Plug supplied permits connections across the line for voltage measurements and in series with the load for current measurements. These connections are clearly shown in Figure 4-1. Figure 5-4 shows the cable connections within the plug.

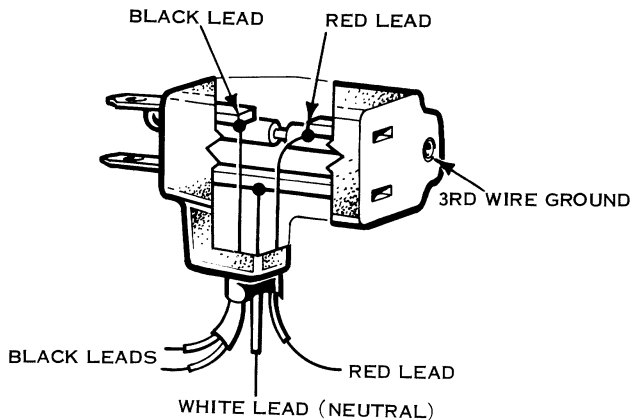

Figure 5-4. Cross Section of Break-In Plug, Showing Cable Connections

## SECTION VI

### MAINTENANCE

#### 6.1 GENERAL

##### WARNING

This Instrument contains internal voltages that constitute a **SHOCK HAZARD** when connected to an AC line. Review the **SHOCK HAZARD** definition on page v. Repairs should be performed only by qualified personnel, preferably a Simpson Authorized Service Center.

The Model 390-2 is constructed with high quality components. By providing reasonable care, and following the instructions in this manual you can expect a long useful service life from this Instrument.

#### 6.2 WARRANTY

The Simpson Electric Company Warranty policy is printed on the inside back cover of this manual. Read it carefully before requesting a warranty repair.

NOTE: For assistance of any kind, including help with the Instrument under warranty, contact your nearest Authorized Service Center for instructions. If you wish to contact the factory directly, give full details of the difficulty and date of purchase. Service data or shipping instructions will be sent to you promptly. If an estimate of charges for non-warranty or other service work is required, a maximum charge estimate will be quoted. This charge will not be exceeded without your prior approval.

#### 6.3 SHIPPING

Pack the Instrument carefully and ship it prepaid to the proper destination. Insure the shipment.

## 6.4 CARE

The Model 390-2 is a very rugged instrument. However, treat it with care as its mechanism is actually more delicate than that of a watch. Keep it clean, free from continuous, severe vibration and avoid dropping it.

## SECTION VII

### ORDERING INFORMATION, SCHEMATIC DIAGRAM AND AUTHORIZED SERVICE CENTERS

#### 7.1 GENERAL

Simpson Authorized Service Centers have been established throughout the United States and Canada. To obtain repair or recalibration for any items of Simpson equipment, contact the nearest Authorized Service Center and make arrangements with them for the service you require. A list of Authorized Service Centers is included on the last pages of this manual.

**Table 7-1. Instrument and List of Items Furnished**

Quantity	Description	Part No.
1	Model 390-2	12481
1	Break-In Cord Assembly	10-863226
1	Operator's Manual	5-118348

**Table 7-2. Replacement Parts List**

Reference Number	Description	Part No.
T1	Transformer	1-112996
S1	Switch Assembly (Amps)	0-008818
S2	Switch Assembly (Watts)	0-008817
R3	Resistor, Spool	10-675189
R1,R2,R5	Resistor, Spool	10-675328
R4	Resistor, Bobbin	10-805200
	Phenolic Case	3-360107
	Meter Cover Assembly	10-560179

Lower Cover	3-230372
Banana Plug	5-131969
Pushbutton	3-310214
Break-In Cord Assembly	10-863226
Test Lead Set with Alligator Clips	07543

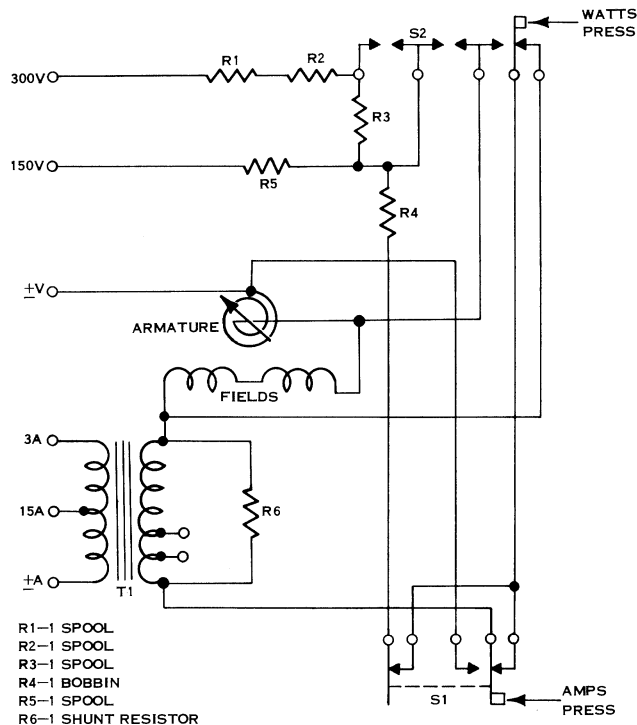

**Figure 7-1. Model 390-2, Schematic Diagram**

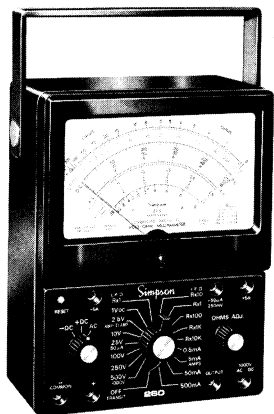

# Simpson® 260® SERIES 6XLP

WITH CIRCUIT OVERLOAD PROTECTION

For The Special Needs  
of the Solid-State  
Electronics Industry

- Extra shock and drop resistant construction  
High impact, custom-molded panel and case
- Extra large viewing area with four color,  
color-keyed scales
- 33 ranges with extra voltage, current, resistance  
and low-power ohms functions
- Plus—all the features of the time-honored,  
ever popular 260-6

## Warranty

SIMPSON ELECTRIC COMPANY warrants each instrument and other articles of equipment manufactured by it to be free from defects in material and workmanship under normal use and service; its obligation under this warranty being limited to making good at its factory any instrument or other article of equipment which shall within 90 days after delivery of such instrument or other article of equipment to the original purchaser be returned intact to it, or to one of its authorized service stations, with transportation charges prepaid, and which its examination shall disclose to its satisfaction to have been thus defective, this warranty being expressly in lieu of all other warranties expressed or implied and of all other obligations or liabilities on its part, and SIMPSON ELECTRIC COMPANY neither assumes nor authorizes any other persons to assume for it any other liability in connection with the sale of its products.

This warranty shall not apply to any instrument or other article of equipment which shall have been repaired or altered outside the SIMPSON ELECTRIC COMPANY factory or authorized service stations, nor which has been subject to misuse, negligence or accident, incorrect wiring by others, or installation or use not in accord with instructions furnished by the manufacturer.



ELECTRIC COMPANY

852 Dundas Ave. E., Dept. 1000, Toronto, Ont. Phone: (416) 697-2760

IN CANADA: Best-Simpson, Ltd., London, Ontario

IN ENGLAND: Best-Simpson (U.K.) Limited, Wellesbourne, Coventry

IN INDIA: Runtunda Simpson Private, Ltd., International House, Bombay-Aga Road, Vikhroli, Bombay



ELECTRIC EQUIPMENT  
SHOP

ORDER FROM YOUR ELECTRONICS/ELECTRICAL DISTRIBUTOR